











TABLES

TABLES

INDEX

GHOST	pag 4	CROSSING	pag 26	WALKING	pag 62	TWIST	pag 86	FREE	pag 100	TRENDY	pag 108	GLAMOUR	pag 120	STYLE	pag 138
															

MOOD	pag 154	SQUARE	pag 180	CURVE	pag 202	BUTTERFLY	pag 206	SLOPING	pag 210	BLOCK	pag 214	TESS VESNA	pag 234
													

GHOST
CROSSING
WALKING
TWIST
FREE
TRENDY
GLAMOUR

L'amore non muore mai

dal manifesto del Dracula di F.F. Coppola

Può una libreria essere un compagno di viaggio? Può un oggetto di legno essere come l'orologio che il nonno dona al nipotino? Qualcosa di prezioso che ti è accanto, che parla di te, che ti racconta ... lo sguardo del tuo cane la sera ... l'immagine che diventa "ricordo che riaffiora" ... un diario ... una storia. Le cose belle, le cose fatte bene, le cose importanti ... le cose che si amano ... sono fatte così... ed è a cose come queste che abbiamo pensato nel creare i mobili Beyond.

Manufatti artigianali, frutto di una storia che parte da lontano per dare inizio ad una storia che ti parlerà da vicino. Spesso non ci accorgiamo, ma quando pensiamo, qualunque sia il nostro pensiero o il nostro sogno ad occhi aperti, lo sguardo si posa sugli oggetti che abbiamo vicino. E' attraverso questo tipo di scambio che gli oggetti assorbono i nostri pensieri e le nostre emozioni e spesso ce li raccontano e e li ricordano.

Anche un mobile, parlerà di te, dei tuoi gesti quotidiani dei tuoi progetti così come dei tuoi sogni lontani.

"Siam fatti della stessa materia dei sogni" dice un personaggio di Shakespeare, e il valore della materia in Beyond è il sogno di costruire con maestria antica, oggetti contemporanei, di essere vivi e vicini ... di essere, proprio nelle intenzioni di chi li fa e di chi li acquista: materia di sogni.



cod. E29G
TAVOLO GHOST, fin. GROOVE / GHOST TABLE, GROOVE fin.
220x100x76H

cod. E29G
TAVOLO GHOST, fin. GROOVE con bordo Scortecciato
GHOST TABLE, GROOVE fin. profile: Natural-Irregular
220x100x76H



“Che mai non muoia di beltà la rosa”

W. Shakespeare

La luce nella foresta di alberi della gomma è densa e soffusa. L'uomo guarda quell'albero che ha poco più di 20 anni.

Segue i solchi lungo la corteccia, creati per far scorrere e raccogliere il lattice.

Guarda quella pianta generosa ma stanca... quel ventenne ormai vecchio... che sta per essere abbattuto.

Al suo posto ne planteranno un altro, che presto comincerà a essere più produttivo e “utile allo scopo”.

Sembra un racconto dal finale triste e invece è l'inizio di una storia bellissima.

L'uomo che guarda quell'albero sa che quel ventenne ormai vecchio sta per rinascere in nuove forme forti ed essenziali, capaci di sfidare i secoli.

Ed è questa storia e queste forme che ti racconteremo.





cod. E27G
TAVOLO GHOST, fin. GROOVE /
GHOST TABLE, GROOVE fin.
180x90x76H

cod. K25S
SEDIA TESS, fin. OAK /
TESS CHAIR, OAK fin.
45x50x87H



cod. K26G
TAVOLO GHOST, fin. OAK /
GHOST TABLE, OAK fin.
160x90x76H

cod. K25S
SEDIA TESS, fin. OAK /
TESS CHAIR, OAK fin.
45x50x87H



cod. K26G
TAVOLO GHOST, fin. OAK / GHOST TABLE, OAK fin.
160x90x76H



cod. X26G
TAVOLO MIX con una gamba Legno e una Vetro



cod. X26G
TAVOLO MIX con una gamba Legno e una Vetro



cod. Z26G
TAVOLO MIX con due gambe Legno

cod. T27G
TAVOLO GHOST, fin. MUST / GHOST TABLE, MUST fin.
180x90x75H





cod. T27G
TAVOLO GHOST, fin. MUST / GHOST TABLE, MUST fin.
180x90x75H



ECO
FRI
END
LY
WO
OD



GHOST

ALLUNGABILE

Tavolo fisso. Optional con una o due prolun-
ghe a fissaggio frontale; fornite separate,
corredate di sacca in tessuto per riporle.

Dimensioni: H 76 cm Oak - Groove

Dimensioni: H 75 cm Must - Wild

Spessore piano: 4 cm Oak - Groove

Spessore piano: 5 cm Must - Wild

Piano fin. Oak - Must con bordo Dritto

Piano fin. Groove - Wild bordo Scortecciato

Prolunga con bordo Dritto

N.B. Per la misura dei piani da 250 cm è
consigliabile predisporre 3 gambe vetro.

EXTENDIBLE

Extending table, with two front-fastening
extensions, supplied separately, together
with fabric storage bag.

Dimensions: H 76 cm Oak - Groove

Dimensions: H 75 cm Must - Wild

Table top thickness: 4 cm Oak - Groove

Table top thickness: 5 cm Must - Wild

OAK - Must finish profile: Square-Linear

GROOVE - Wild finish profile: Natural-

Irregular

Leaf with linear profile

VERLÄNGERBAR

Fester Tisch mit oder zwei Verlängerungplatten
die am Tischende befestigt werden. Auf-
bewahrung der Ansteckplatten, in einem
Stoffsack.

Maße: H 76 cm Oak - Groove

Maße: H 75 cm Must - Wild

Dicke der Platte: 4 cm Oak - Groove

Dicke der Platte: 5 cm Must - Wild

Dimensioni / Dimensions / Maße

Chiuso / Closed / Geschlossen

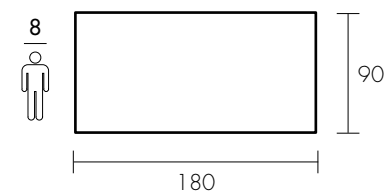

Aperto (1 allunghe) / Open (1 ext.) / Offen (1 Verlängerung)

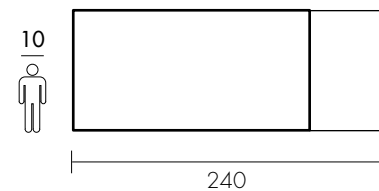

Aperto (2 allunghe) / Open (2 ext.) / Offen (2 Verlängerungen)

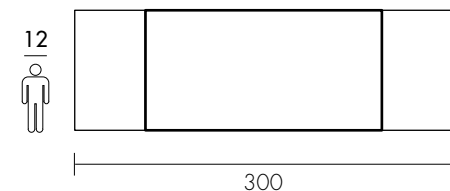
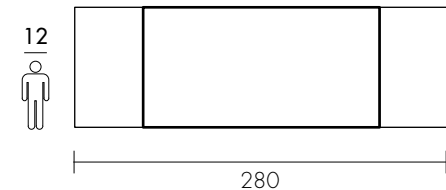

GHOST
CROSSING

WALKING

TWIST

FREE

TRENDY

GLAMOUR

Anche l'occhio ha la sua parte

C'è ancora un uomo che guarda, in questa storia. E' l'uomo che studia tutte le venature, i disegni e le composizioni sulla superficie delle tavole. I nodi, le sfumature, le striature ... ogni tavola è come il tassello di un puzzle, da studiare bene per creare combinazioni perfette e uniche.

Tutto è affidato alla maestria e al talento di quell'uomo e dei suoi compagni di lavoro. Ogni pezzo raggruppato, scelto e combinato di quel legno è destinato a diventare un mobile di rara eccellenza.

C'è chi lo chiama "massiccio" e chi lo chiama "massello" ma il significato è abbastanza chiaro e indica il legno utilizzato per realizzare mobili di grande qualità, destinati a durare nel tempo.

Ogni creazione Beyond è contrassegnata da questo termine. La cura nella scelta, le attenzioni nella lavorazione e il design sono le uniche cose aggiunte al valore del legno.

Tutto naturale, niente di rifatto. Ma c'è un'altra cosa che contraddistingue e caratterizza questi mobili: la tradizione. L'azienda che li produce è da sempre conosciuta per la maestria nella lavorazione del mobile classico (destinazione principale del legno massello) ed è da questa importante esperienza che nasce una collezione contemporanea come Beyond.

Qualità della lavorazione e qualità del design, quante volte si è sentita una frase come questa? Eppure in Beyond non è un modo di dire, ma un modo di fare.



cod. E29S
TAVOLO CROSSING, fin. GROOVE / CROSSING TABLE, GROOVE fin.
220x100x76H



MO
DE
RN
DE
SI
GN



cod. E29S
TAVOLO CROSSING, fin. GROOVE / CROSSING TABLE, GROOVE fin.
220x100x76H



LEG
NO
NA
TU
RA
LE

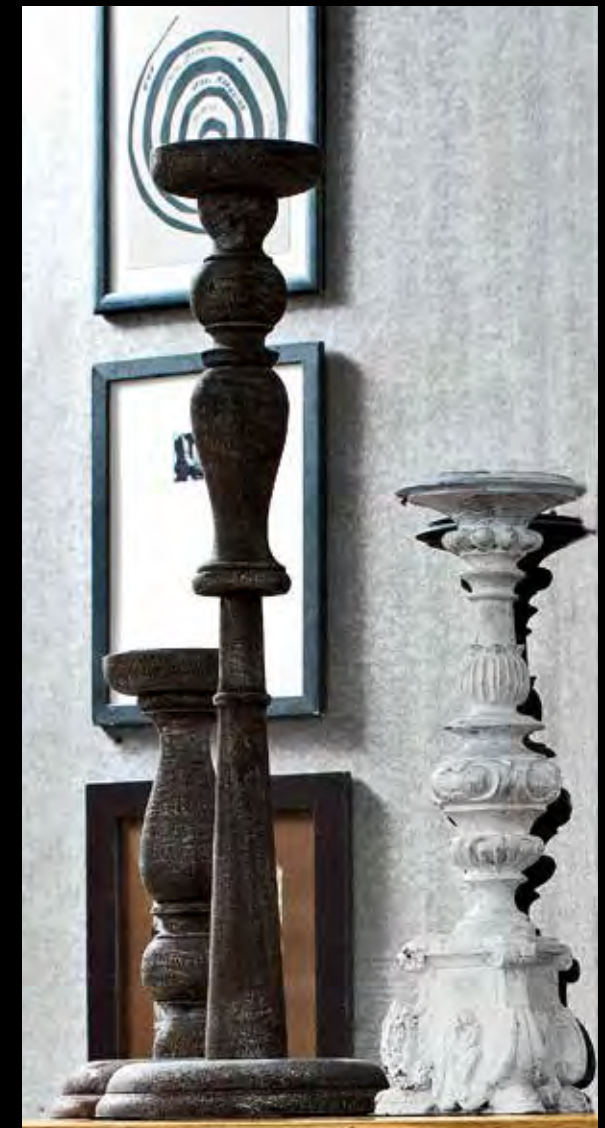

cod. E475
TAVOLO CROSSING Estensibile, fin. GROOVE / Extensible CROSSING TABLE, GROOVE fin.
180x90x76H allungato 280



Un re di legno

C'era una volta un re di legno.
La testa di legno,
la corona di legno,
Era tutto di legno, perché
era soltanto la statua di un re.
I tarli gli sforacchiavano il manto,
i ragni tessavano la tela
tra il naso e l'orecchio.
Era di legno, ed era anche assai vecchio.
Era così vecchia, la statua di quel re,
che il re di quella statua
era già morto, sepolto e consumato
in fondo al tempo passato,
dove vanno i re veri
con tutto il loro regno
e dove non vanno
le statue di legno.

cod. E475
TAVOLO CROSSING Estensibile, fin. GROOVE / Extensible CROSSING TABLE, GROOVE fin.
180x90x76H allungato 280



cod. E47S
TAVOLO CROSSING Estensibile, fin. GROOVE / Extensible CROSSING TABLE, GROOVE fin.
180x90x76H allungato 280



cod. E29C
PANCA PIEDE LEGNO LATERALE, spessore piano e struttura 40 mm, fin. GROOVE
BENCH WOOD LEGS, structure and top thickness 40 mm, GROOVE fin.
190x40x45H



EX
TEN
SIBLE
TA
BLE







cod. D275
TAVOLO CROSSING, fin. WILD / CROSSING TABLE, WILD fin.
180x90x75H



Finitura WILD / WILD Finish
Piano in Legno Massello
Lavorazione Piano con Piattatura a Mano
Spessore piano 50mm (25 Piano + 25 Ring)

cod. D27S
TAVOLO CROSSING, fin. WILD / CROSSING TABLE
180x90x75H



LIFE NATURAL



cod. D27S
TAVOLO CROSSING, fin. WILD / CROSSING TABLE, WILD fin.
180x90x75H



cod. K33S
TAVOLO CROSSING, fin. OAK, piano sagomato / CROSSING TABLE, OAK fin., shaped top table
200x110x76H



PASSION

Each piece of FGF furniture has a history based on people working hand-in-hand with nature. When someone purchases FGF, they allow a bit of "green" to enter their home, which has been molded by skillful human hands that transform the natural beauty of raw materials into the art of furniture.

Our customers can rest assured that our furniture is one of a kind and unique, and that the beauty that only real wood can offer will be enjoyed for many years to follow.

HOME

Our products have all been designed to be destined for the home. This everyday living space provides warmth and protection, and reflects the individual tastes and personality of the people that live in it.

The choice to furnish our home with quality wood products is a decision that is usually based on personal needs and passion.

Our customers tend to feel privileged when they chose FGF furniture, because they love and appreciate the natural beauty of wood and fine skilled craftsmanship, which are the main features behind our products.





cod. K33S
TAVOLO CROSSING, fin. OAK, piano sagomato / CROSSING TABLE, OAK fin., shaped top table
200x110x76H



cod. K33S
TAVOLO CROSSING, fin. OAK,
piano sagomato
CROSSING TABLE, OAK fin.,
shaped top table
200x110x76H

CROSSING

FISSO + PROLUNGA

Tavolo fisso. Optional con una o due prolun-
ghe a fissaggio frontale; fornite separate,
corredate di sacca in tessuto per riporle.
Dimensioni: H 76 cm Oak - Groove
Dimensioni: H 75 cm Must - Wild
Spessore piano: 4 cm Oak - Groove
Spessore piano: 5 cm Must - Wild
Piano fin. Oak - Must con bordo Dritto
Piano fin. Groove - Wild bordo Scortecciato
Prolunga con bordo Dritto

EXTENDIBLE

Extending table, with two front-fastening
extensions, supplied separately, together
with fabric storage bag.
Dimensions: H 76 cm Oak - Groove
Dimensions: H 75 cm Must - Wild
Table top thickness: 4 cm Oak - Groove
Table top thickness: 5 cm Must - Wild
OAK - Must finish profile: Square-Linear
GROOVE - Wild finish profile: Natural-
Irregular
Leaf with linear profile

VERLÄNGERBAR

Fester Tisch mit oder zwei Verlängerungplatten
die am Tische befestigt werden. Auf-
bewahrung der Ansteckplatten, in einem
Stoffsack.
Maße: H 76 cm Oak - Groove
Maße: H 75 cm Must - Wild
Dicke der Platte: 4 cm Oak - Groove
Dicke der Platte: 5 cm Must - Wild

ESTENSIBILE

Tavolo estensibile con allunghe interne.
Optional una prolunga a fissaggio frontale;
corredate di sacca in tessuto per riporla.
Dimensioni: H 76 cm Oak - Groove
Dimensioni: H 75 cm Must - Wild
Spessore piano: 4 cm Oak - Groove
Spessore piano: 5 cm Must - Wild
Piano fin. Oak - Must con bordo Dritto
Piano fin. Groove - Wild bordo Scortecciato
Prolunga con bordo Dritto

EXTENDIBLE

Extending table, with two extensions,
supplied inside the structure of the table.
Dimensions: H 76 cm Oak - Groove
Dimensions: H 75 cm Must - Wild
Table top thickness: 4 cm Oak - Groove
Table top thickness: 5 cm Must - Wild
OAK - Must finish profile: Square-Linear
GROOVE - Wild finish profile: Natural-
Irregular
Leaf with linear profile

VERLÄNGERBAR

Fester Tisch mit oder zwei Verlängerungplatten
die am Tische befestigt werden.
Maße: H 76 cm Oak - Groove
Maße: H 75 cm Must - Wild
Dicke der Platte: 4 cm Oak - Groove
Dicke der Platte: 5 cm Must - Wild

Dimensioni / Dimensions / Maße

Chiuso / Closed / Geschlossen

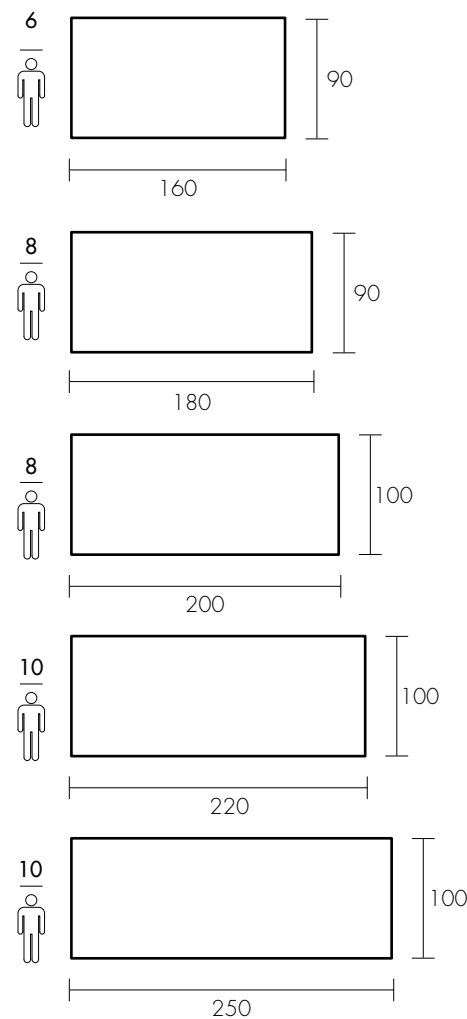

Aperto (1 allunga) / Open (1 ext.) / Offen (1 Verlängerung)

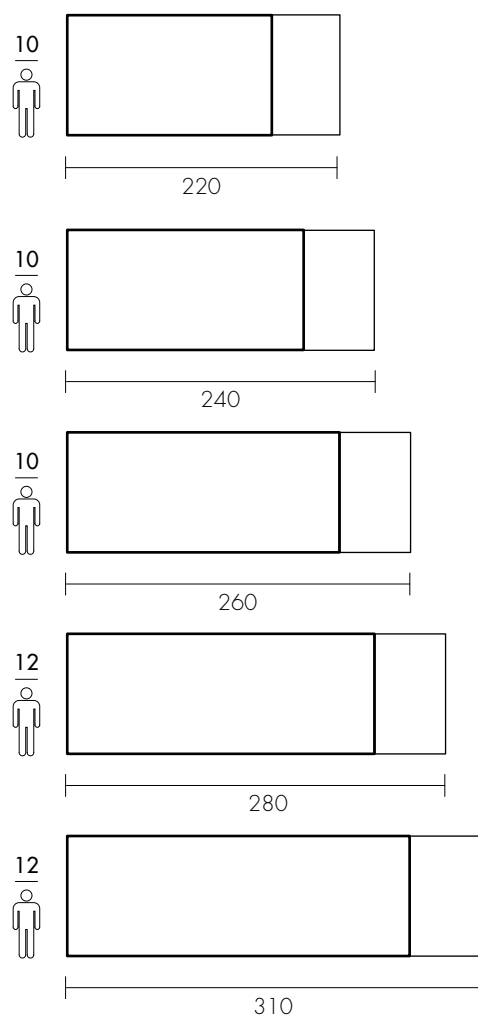

Aperto (2 allunghe) / Open (2 ext.) / Offen (2 Verlängerungen)

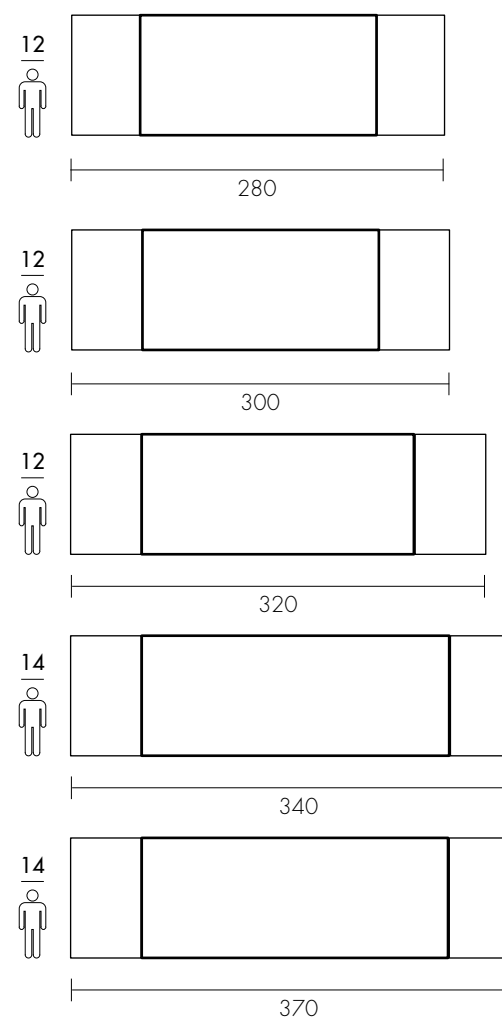

Dimensioni / Dimensions / Maße

Chiuso / Closed / Geschlossen

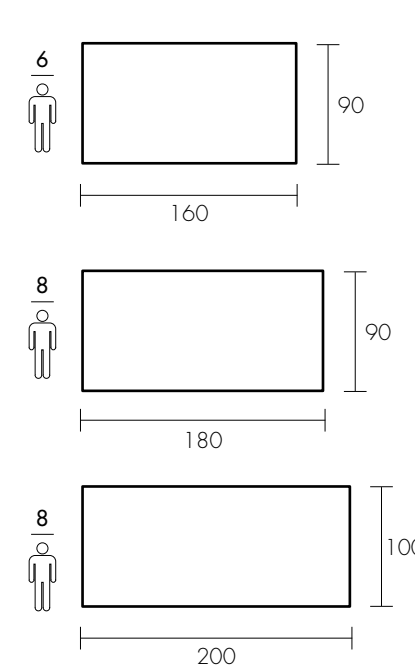

Aperto (1 allunga) / Open (1 ext.) / Offen (1 Verlängerung)

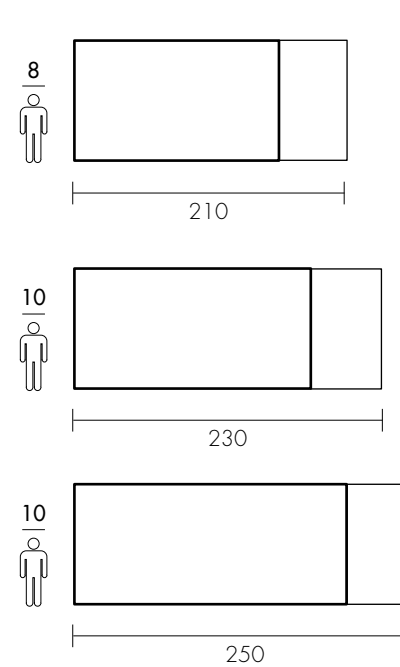

Aperto (2 allunghe) / Open (2 ext.) / Offen (2 Verlängerungen)

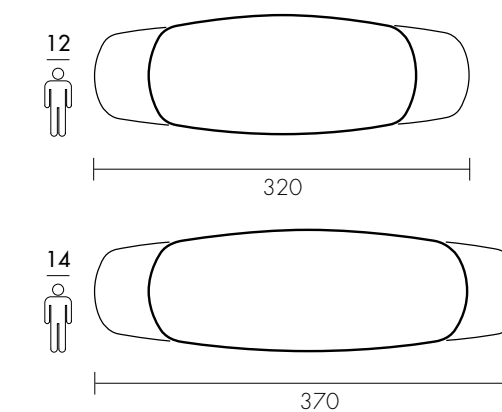
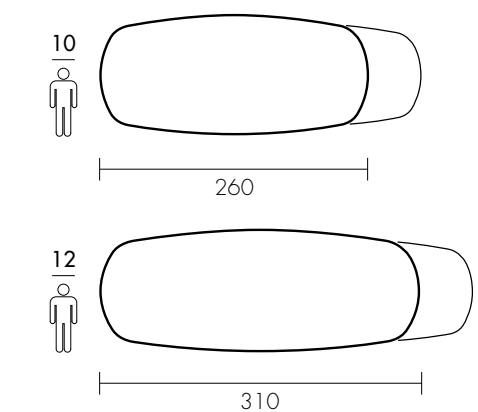
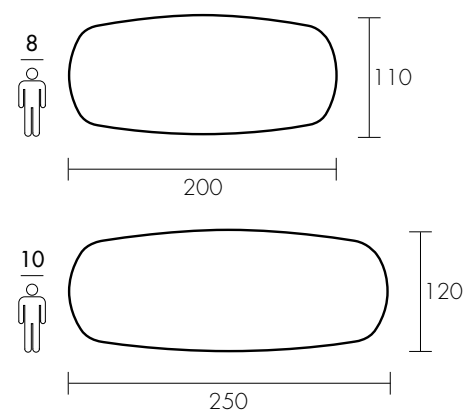
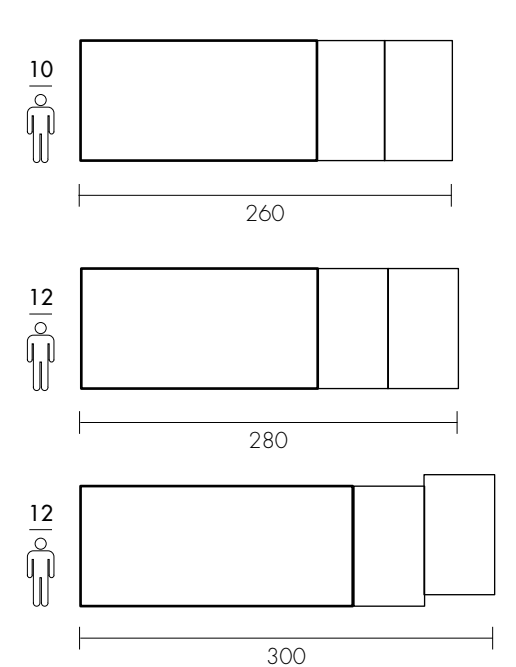

GHOST
CROSSING

WALKING

TWIST

FREE

TRENDY

GLAMOUR

Ode all'odore della legna

Pablo Neruda

Tardi, con le stelle aperte nel freddo aprii la porta.
Il mare galoppava nella notte.

Come una mano dalla casa oscura
uscì l'aroma intenso della legna custodita.

L'aroma era visibile come se l'albero fosse vivo.
Come se ancora palpitasse. Visibile come una veste.

Visibile come un ramo sferzato.
Girai dentro la casa circondato da quella balsamica oscurità.

Fuori le punte del cielo scintillavano come pietre magnetiche,
e l'odore della legna mi toccava il cuore con dita,
come di gelsomino, come di alcuni ricordi.

Non era l'odore acuto dei pini, no,
non era la scalfitura nella pelle dell'eucalipto,
non erano neppure i profumi verdi della vigna,
ma qualcosa di più segreto, perché quella fragranza una sola,
una sola volta esisteva, e lì, di tutto ciò che vidi nel mondo,
nella mia stessa casa, di notte, presso il mare d'inverno,
lì stava attendendomi l'odore della rosa più profonda,
il cuore reciso della terra

qualcosa che m'invase come un'onda staccata dal tempo
e si perse in me stesso quando aprii la porta della notte.





Molto si crea e nulla si distrugge

Havea brasiliensis è il suo nome latino, Rubberwood il suo nome comune, Parawood è il suo nome tecnico, ma in tutto il mondo è conosciuto come l'albero della gomma. Piantato dall'uomo per ottenere lattice, ha una vita produttiva di circa 25 anni.

Dopo il periodo di massima resa gli alberi vengono sostituiti ma non per questo smettono di essere utili ed importanti. Dopo aver fornito lattice prezioso, infatti, questi alberi sono già pronti per fornire un legno altrettanto prezioso.

Un legno duro, e per questo di grande valore per chi costruisce mobili di prestigio. Un legno dal colore chiaro, che può essere tinto in maniera ottimale. Non viene quindi distrutta nessuna foresta e quella che viene sostituita, sarà trasformata in mobili Belli e Solidi.

Una delle più importanti frasi della saggezza umana recita: "Nulla si crea e nulla si distrugge, ma tutto si trasforma".

Creare cose belle senza distruggere cose importanti (come l'ambiente), è una delle cose più sagge che oggi possiamo fare.



cod. E29W
TAVOLO WALKING, fin. GROOVE / WALKING TABLE, GROOVE fin.
220x100x76H



SCORTECCIA IA TO



cod. E29W
TAVOLO WALKING, fin. GROOVE / WALKING TABLE, GROOVE fin.
220x100x76H

cod. K33W
TAVOLO WALKING, fin. OAK, piano sagomato / WALKING TABLE, OAK fin., shaped top table
200x110x76H





cod. K33W
TAVOLO WALKING, fin. OAK, piano sagomato / WALKING TABLE, OAK fin., shaped top table
200x110x76H



cod. K33W
TAVOLO WALKING, fin. OAK, piano sagomato
WALKING TABLE, OAK fin., shaped top table
200x110x76H







cod. K33W
TAVOLO WALKING, fin. OAK, piano sagomato / WALKING TABLE, OAK fin., shaped top table
200x110x76H

WALKING

FISSO + PROLUNGA

Tavolo fisso. Optional con una o due prolun-
ghe a fissaggio frontale; fornite separate,
corredate di sacca in tessuto per riporle.

Dimensioni: H 76 cm Oak - Groove

Dimensioni: H 75 cm Must - Wild

Spessore piano: 4 cm Oak - Groove

Spessore piano: 5 cm Must - Wild

Piano fin. Oak - Must con bordo Dritto

Piano fin. Groove - Wild bordo Scortecciato

Prolunga con bordo Dritto

EXTENDIBLE

Extending table, with two front-fastening
extensions, supplied separately, together
with fabric storage bag.

Dimensions: H 76 cm Oak - Groove

Dimensions: H 75 cm Must - Wild

Table top thickness: 4 cm Oak - Groove

Table top thickness: 5 cm Must - Wild

OAK - Must finish profile: Square-Linear

GROOVE - Wild finish profile: Natural-

Irregular

Leaf with linear profile

VERLÄNGERBAR

Fester Tisch mit oder zwei Verlängerungplatten
die am Tischende befestigt werden. Auf-
bewahrung der Ansteckplatten, in einem
Stoffsack.

Maße: H 76 cm Oak - Groove

Maße: H 75 cm Must - Wild

Dicke der Platte: 4 cm Oak - Groove

Dicke der Platte: 5 cm Must - Wild

FISSO + PROLUNGA

Tavolo fisso. Optional con una o due prolun-
ghe a fissaggio frontale; fornite separate,
corredate di sacca in tessuto per riporle.

Dimensioni: H 76 cm

Spessore piano: 4 cm

Piano sagomato fin. Oak - Groove

Prolunga con bordo Dritto

EXTENDIBLE

Extending table, with two front-fastening
extensions, supplied separately, together
with fabric storage bag.

Dimensions: H 76 cm

Table top thickness: 4 cm

Shaped profile: OAK - GROOVE

Leaf with linear profile

VERLÄNGERBAR

Fester Tisch mit oder zwei Verlängerungplatten
die am Tischende befestigt werden. Auf-
bewahrung der Ansteckplatten, in einem
Stoffsack.

Maße: H 76 cm

Dicke der Platte: 4 cm Oak - Groove

Dimensioni / Dimensions / Maße

Chiuso / Closed / Geschlossen

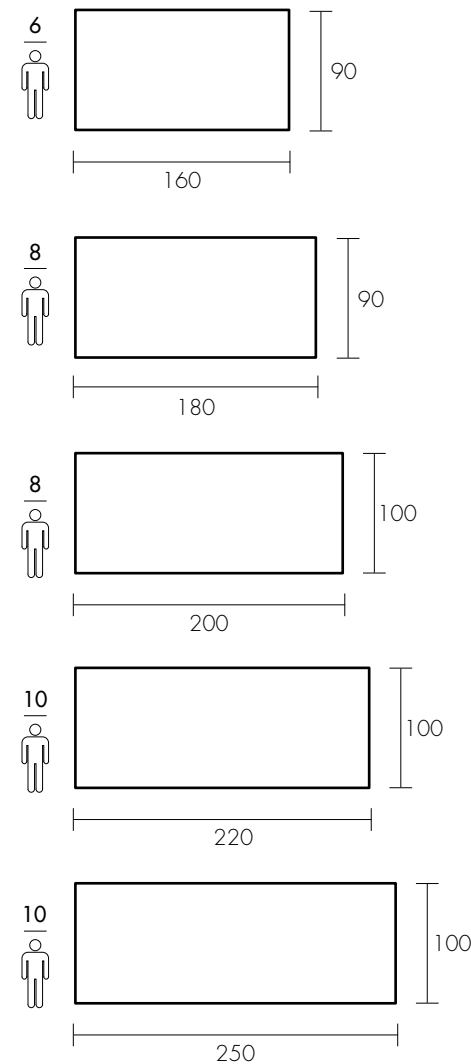

Aperto (1 allunga) / Open (1 ext.) / Offen (1 Verlängerung)

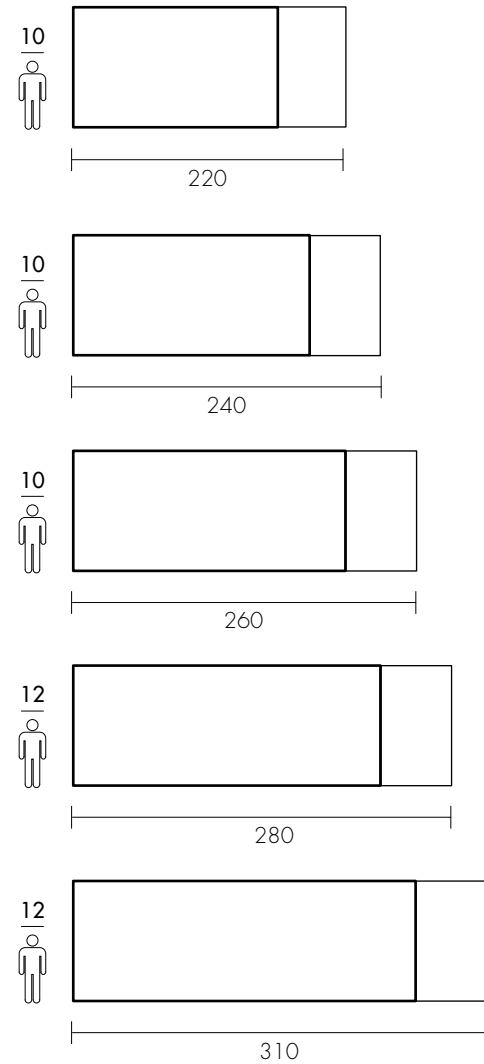

Aperto (2 allunghe) / Open (2 ext.) / Offen (2 Verlängerungen)

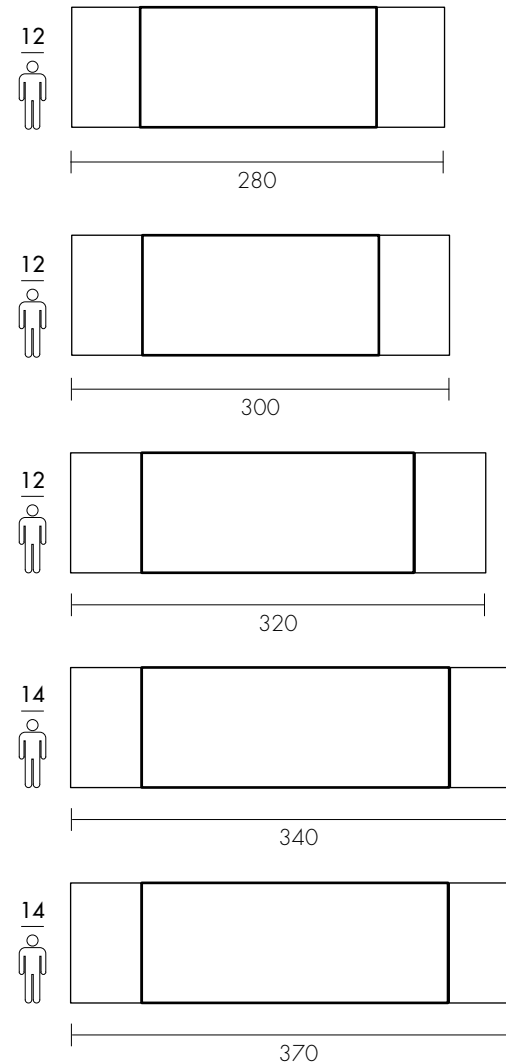

Chiuso / Closed / Geschlossen

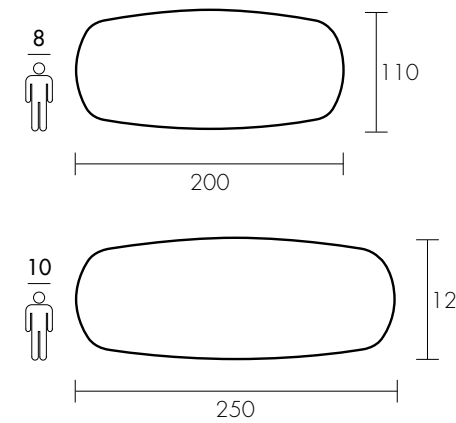

Aperto (1 allunga) / Open (1 ext.) / Offen (1 Verlängerung)

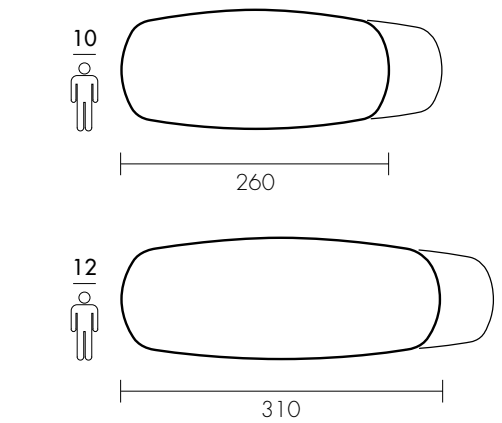

Aperto (2 allunghe) / Open (2 ext.) / Offen (2 Verlängerungen)

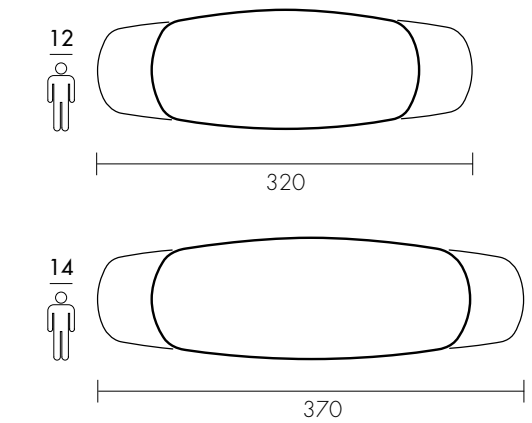

GHOST
CROSSING
WALKING
TWIST
FREE
TRENDY
GLAMOUR

Profumi e colori del legno

P. Tommasi, scultore

Ogni qualvolta che,
sotto i colpi della sgorbia
nugoli di schegge
mettono a nudo
l'anima della ceppa,
ne sprigionano l'interna essenza,
e ne rivelano l'inaspettato colore,
alla gioia dello scultore
che vede nascere, colpo su colpo,
dall'inerte ciocco
la forma già impressa nella mente,
si aggiungono altre sensazioni:
il gradevole profumo
che emana da un legno
apparentemente morto,
la vista dei bei colori
che appaiono sotto la scorza,
la venatura dell'olivo,
il purpureo del pino,
il biancore del cipresso, del faggio
tutti con i rispettivi aromi,
sono per l'intagliatore
come una panacea
che trasforma in poesia
la fatica dello scolpire il legno

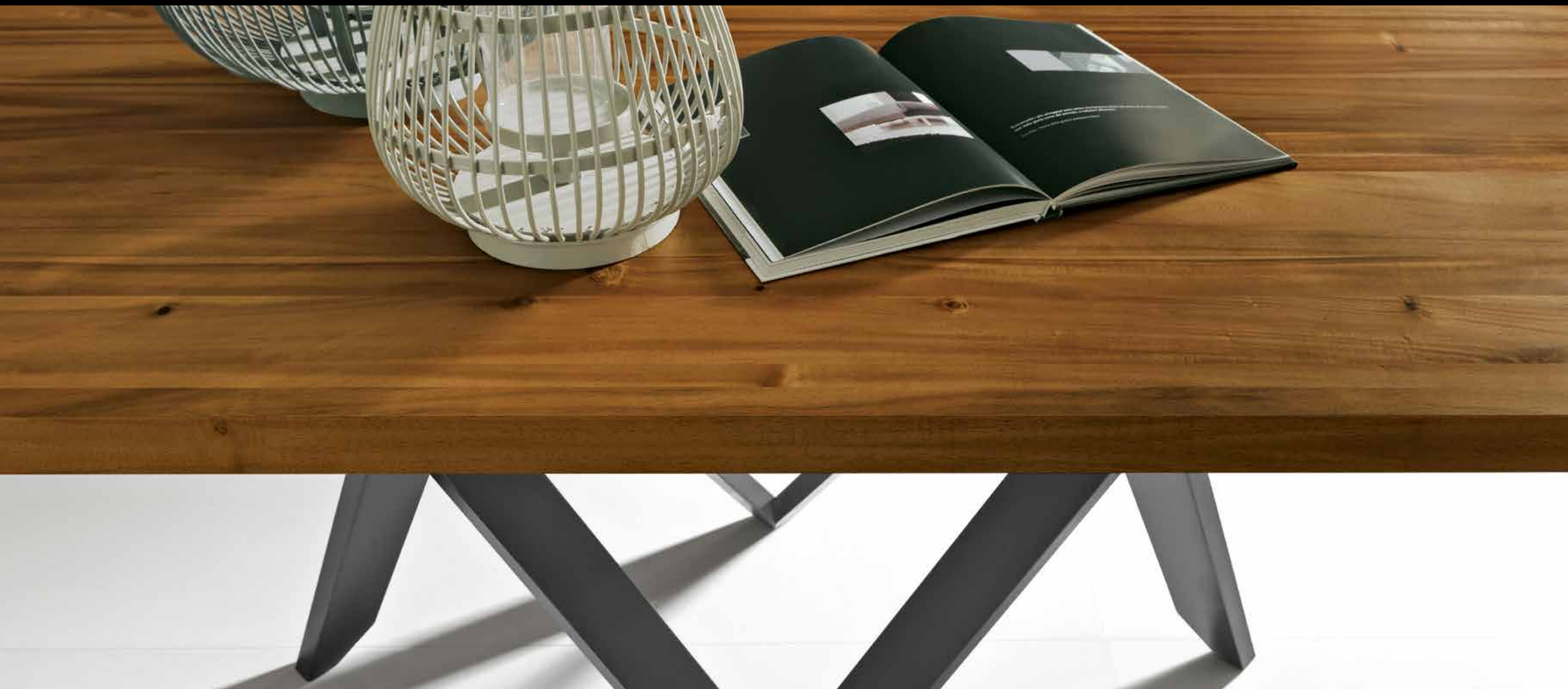

cod. T27T
TAVOLO TWIST, fin. MUST / TWIST TABLE, MUST fin.
180x90x75H





ONLY
SOLID
WOOD







cod. T27T
TAVOLO TWIST, fin. MUST / TWIST TABLE, MUST fin.
180x90x75H

TWIST

ALLUNGABILE

Tavolo fisso. Optional con una o due prolun-
ghe a fissaggio frontale; fornite separate,
corredate di sacca in tessuto per riporle.

Dimensioni: H 76 cm Oak - Groove

Dimensioni: H 75 cm Must - Wild

Spessore piano: 4 cm Oak - Groove

Spessore piano: 5 cm Must - Wild

Piano fin. Oak - Must con bordo Dritto

Piano fin. Groove - Wild bordo Scortecciato

Prolunga con bordo Dritto

EXTENDIBLE

Extending table, with two front-fastening
extensions, supplied separately, together
with fabric storage bag.

Dimensions: H 76 cm Oak - Groove

Dimensions: H 75 cm Must - Wild

Table top thickness: 4 cm Oak - Groove

Table top thickness: 5 cm Must - Wild

OAK - Must finish profile: Square-Linear

GROOVE - Wild finish profile: Natural-

Irregular

Leaf with linear profile

VERLÄNGERBAR

Fester Tisch mit oder zwei Verlängerungplatten
die am Tischende befestigt werden. Auf-
bewahrung der Ansteckplatten, in einem
Stoffsack.

Maße: H 76 cm Oak - Groove

Maße: H 75 cm Must - Wild

Dicke der Platte: 4 cm Oak - Groove

Dicke der Platte: 5 cm Must - Wild

Dimensioni / Dimensions / Maße

Chiuso / Closed / Geschlossen

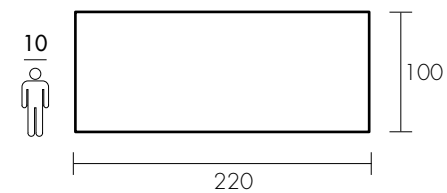
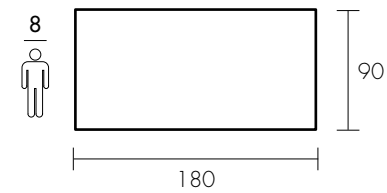

Aperto (1 allunghe) / Open (1 ext.) / Offen (1 Verlängerung)

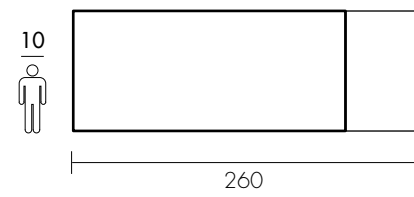
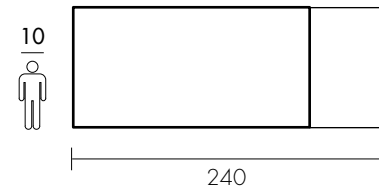
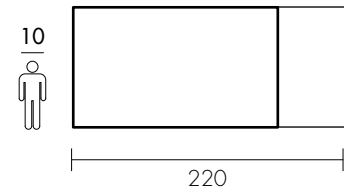

Aperto (2 allunghe) / Open (2 ext.) / Offen (2 Verlängerungen)

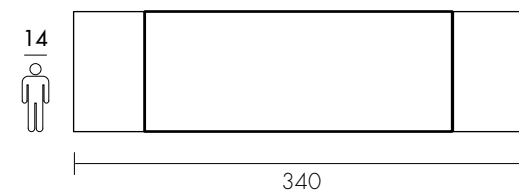
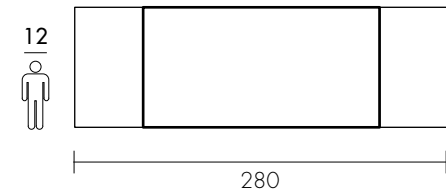

GHOST
CROSSING
WALKING
TWIST
FREE
TRENDY
GLAMOUR

Un re di legno

C'era una volta un re di legno.
La testa di legno,
la corona di legno,
Era tutto di legno, perché
era soltanto la statua di un re.
I tarli gli sforacchiavano il manto,
i ragni tessavano la tela
tra il naso e l'orecchio.
Era di legno, ed era anche assai vecchio.
Era così vecchia, la statua di quel re,
che il re di quella statua
era già morto, sepolto e consumato
in fondo al tempo passato,
dove vanno i re veri
con tutto il loro regno
e dove non vanno
le statue di legno.



cod. E29F
TAVOLO FREE, fin. GROOVE / FREE TABLE, GROOVE fin.
220x100x76H



N
A
T
U
R
A
L
W
O
O
D



FREE

ALLUNGABILE

Tavolo fisso. Optional con una o due prolun-
ghe a fissaggio frontale; fornite separate,
corredate di sacca in tessuto per riporle.

Dimensioni: H 76 cm Oak - Groove

Dimensioni: H 75 cm Must - Wild

Spessore piano: 4 cm Oak - Groove

Spessore piano: 5 cm Must - Wild

Piano fin. Oak - Must con bordo Dritto

Piano fin. Groove - Wild bordo Scortecciato

Prolunga con bordo Dritto

EXTENDIBLE

Extending table, with two front-fastening
extensions, supplied separately, together
with fabric storage bag.

Dimensions: H 76 cm Oak - Groove

Dimensions: H 75 cm Must - Wild

Table top thickness: 4 cm Oak - Groove

Table top thickness: 5 cm Must - Wild

OAK - Must finish profile: Square-Linear

GROOVE - Wild finish profile: Natural-

Irregular

Leaf with linear profile

VERLÄNGERBAR

Fester Tisch mit oder zwei Verlängerungplatten
die am Tischende befestigt werden. Auf-
bewahrung der Ansteckplatten, in einem
Stoffsack.

Maße: H 76 cm Oak - Groove

Maße: H 75 cm Must - Wild

Dicke der Platte: 4 cm Oak - Groove

Dicke der Platte: 5 cm Must - Wild

Dimensioni / Dimensions / Maße

Chiuso / Closed / Geschlossen

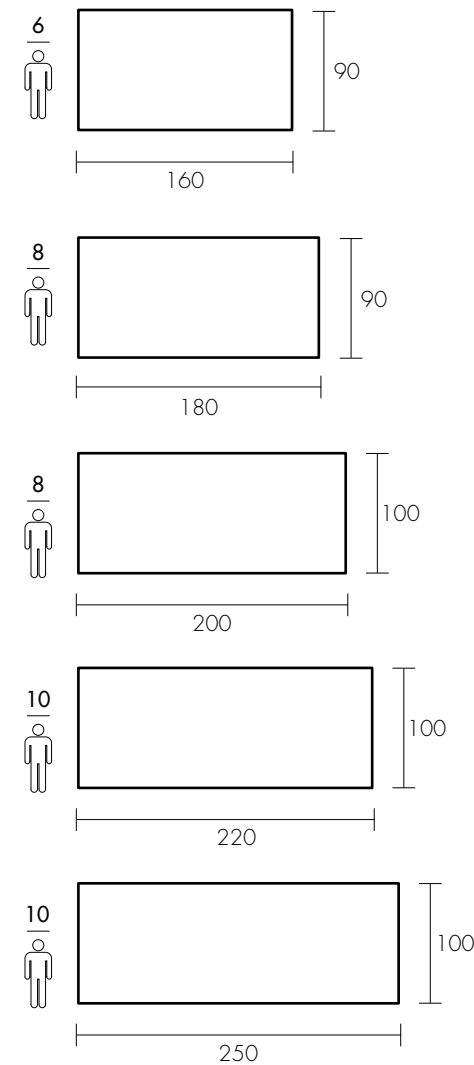

Aperto (1 allunghe) / Open (1 ext.) / Offen (1 Verlängerung)

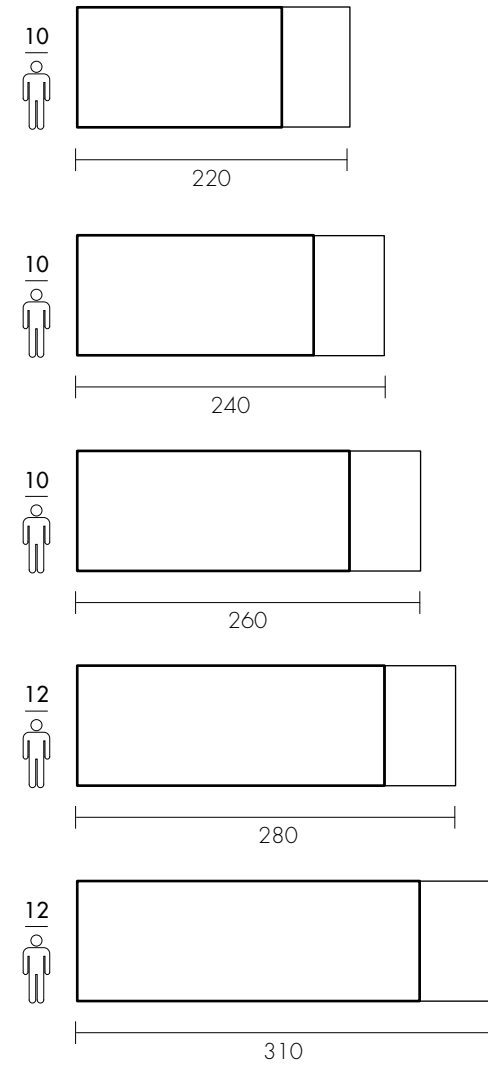

Aperto (2 allunghe) / Open (2 ext.) / Offen (2 Verlängerungen)

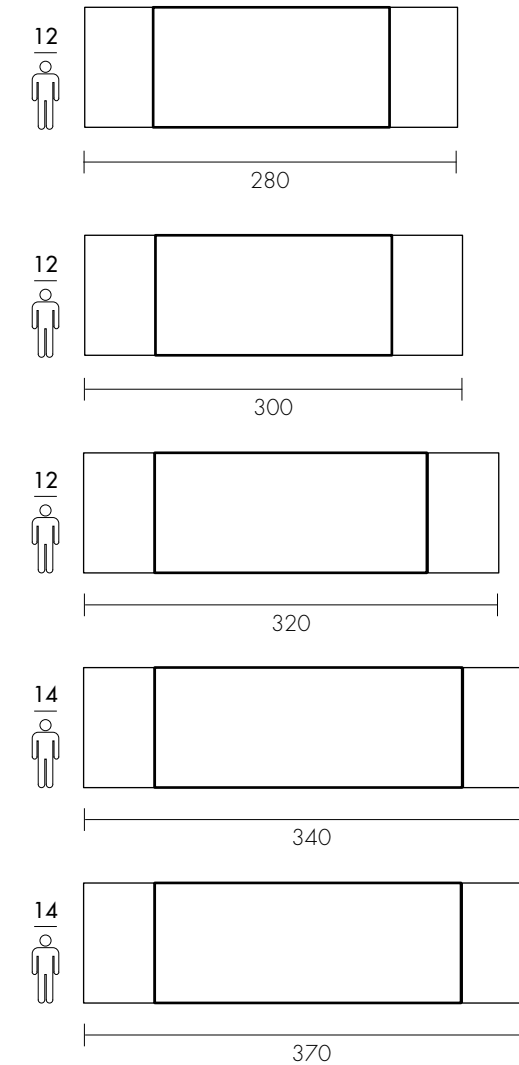

GHOST
CROSSING
WALKING
TWIST
FREE
TRENDY
GLAMOUR

Legno e carezze

Douglas Malloch, *Il buon legname*, 1877-1938

Legno e carezze
Le tue mani si posano
sul legno.
Lavorano, potenti,
calme.

Liberano fiabe
da venature secche.
Lisciano nodi antichi
con una carezza.

Ti guardo.

Vorrei essere legno
fra le tue mani.

Il buon legname non cresce con facilità: / più forte è il vento e
più forti sono gli alberi, / più lontano è il cielo e più alte sono le
piante, / più violenta è la tempesta e più grande è la forza.





cod. E29Y
TAVOLO TRENDY, fin. GROOVE / TRENDY TABLE, GROOVE fin.
220x100x76H



cod. E29Y
TAVOLO TRENDY, fin. GROOVE / TRENDY TABLE, GROOVE fin.
220x100x76H



TRENDY

ALLUNGABILE

Tavolo fisso. Optional con una o due prolun-
ghe a fissaggio frontale; fornite separate,
corredate di sacca in tessuto per riporle.

Dimensioni: H 76 cm Oak - Groove

Dimensioni: H 75 cm Must - Wild

Spessore piano: 4 cm Oak - Groove

Spessore piano: 5 cm Must - Wild

Piano fin. Oak - Must con bordo Dritto

Piano fin. Groove - Wild bordo Scortecciato

Prolunga con bordo Dritto

EXTENDIBLE

Extending table, with two front-fastening
extensions, supplied separately, together
with fabric storage bag.

Dimensions: H 76 cm Oak - Groove

Dimensions: H 75 cm Must - Wild

Table top thickness: 4 cm Oak - Groove

Table top thickness: 5 cm Must - Wild

OAK - Must finish profile: Square-Linear

GROOVE - Wild finish profile: Natural-

Irregular

Leaf with linear profile

VERLÄNGERBAR

Fester Tisch mit oder zwei Verlängerungplatten
die am Tischende befestigt werden. Auf-
bewahrung der Ansteckplatten, in einem
Stoffsack.

Maße: H 76 cm Oak - Groove

Maße: H 75 cm Must - Wild

Dicke der Platte: 4 cm Oak - Groove

Dicke der Platte: 5 cm Must - Wild

Dimensioni / Dimensions / Maße

Chiuso / Closed / Geschlossen

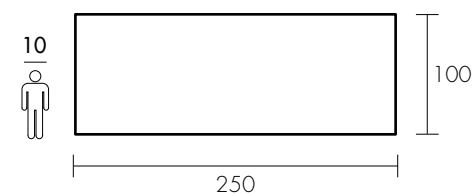
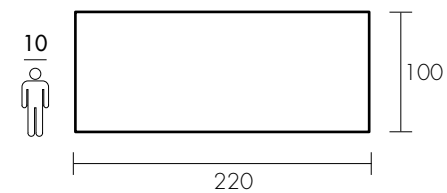

Aperto (1 allunghe) / Open (1 ext.) / Offen (1 Verlängerung)

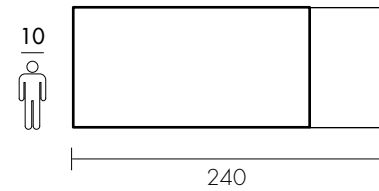
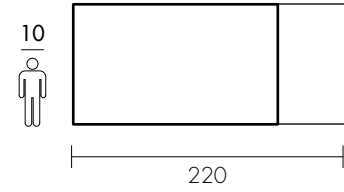

Aperto (2 allunghe) / Open (2 ext.) / Offen (2 Verlängerungen)

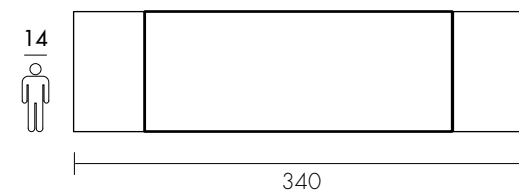
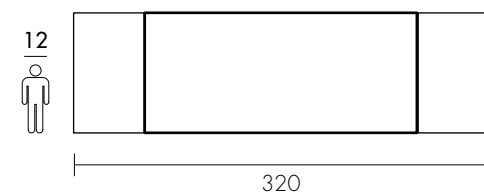
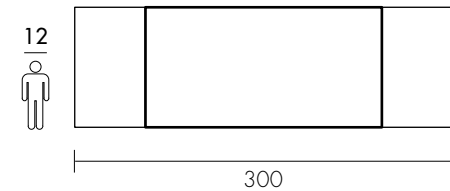

GHOST
CROSSING
WALKING
TWIST
FREE
TRENDY
GLAMOUR

L'immortale legno

Chi mi scava il tronco
separato dalla storia alle radici
ruba i miei occhi alla bellezza

Una luce di conifere straniere
di salici piangenti
oppure è il tronco di una nostrana quercia?

È il ricordo di fronde
di rifugi ricavati asportando cortecce
una scorza che dura nel tempo

Chi mi racconta l'immortalità
non ha visto le ombre spezzate
ed i rossi che macchiano il bianco

Non conosce le albe incise sul legno
ed aspetta che la vita lo assalga
prima di scivolare dentro nuove cavità.

Le radici hanno linfa e sangue vitale
mi attraversano nell'oscurità
troppo bianca per farmi paura.

Quanti sono i segreti del legno
di una quercia o di un pioppo
nessuno lo sa!



cod. E35A
TAVOLO GLAMOUR, fin. GROOVE, piano sagomato / GLAMOUR TABLE, GROOVE fin., shaped top table
250x120x76H



ECO-FRIENDLY

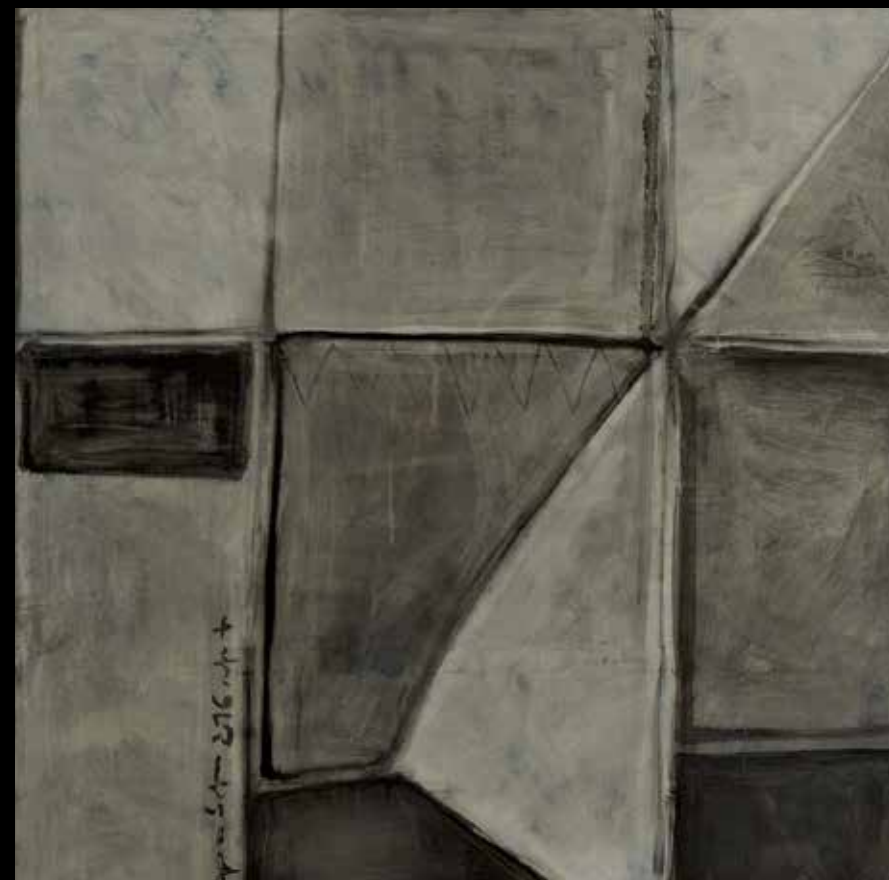



LINEE
REGOLARI



cod. E35A
TAVOLO GLAMOUR, fin. GROOVE, piano sagomato
GLAMOUR TABLE, GROOVE fin., shaped top table
250x120x76H



MATERIAL

There are numerous reasons to act ecologically in our current modern world. This is the main reason why we think it is of utmost importance to use materials that are EcoFriendly.

Our products are of exceptional quality and enhanced by the natural beauty of wood. The global interest in keeping our planet "green" by respecting forests that generate this precious natural resource is part of our mission.

DESIGN

The design of our furniture can be defined in 2 words: Design Forever.

Most of our furniture is distinguished by true elegance and simplicity, which provide beauty that stand the test of time.

Furthermore, our Box collection gives one the freedom to choose different components, so that the end result can be tailored to meet individual functional and esthetic needs.



cod. E969
PROLUNGA SAGOMATA 60cm, GROOVE
in foto 2 prolunghe
in the photo two SHAPED LEAFS



GLAMOUR

FISSO + PROLUNGA

Tavolo fisso. Optional con una o due prolun-
ghe a fissaggio frontale; fornite separate,
corredate di sacca in tessuto per riporle.

Dimensioni: H 76 cm Oak - Groove

Dimensioni: H 75 cm Must - Wild

Spessore piano: 4 cm Oak - Groove

Spessore piano: 5 cm Must - Wild

Piano fin. Oak - Must con bordo Dritto

Piano fin. Groove - Wild bordo Scortecciato

Prolunga con bordo Dritto

EXTENDIBLE

Extending table, with two front-fastening
extensions, supplied separately, together
with fabric storage bag.

Dimensions: H 76 cm Oak - Groove

Dimensions: H 75 cm Must - Wild

Table top thickness: 4 cm Oak - Groove

Table top thickness: 5 cm Must - Wild

OAK - Must finish profile: Square-Linear

GROOVE - Wild finish profile: Natural-

Irregular

Leaf with linear profile

VERLÄNGERBAR

Fester Tisch mit oder zwei Verlängerungplatten
die am Tischende befestigt werden. Auf-
bewahrung der Ansteckplatten, in einem
Stoffsack.

Maße: H 76 cm Oak - Groove

Maße: H 75 cm Must - Wild

Dicke der Platte: 4 cm Oak - Groove

Dicke der Platte: 5 cm Must - Wild

FISSO + PROLUNGA

Tavolo fisso. Optional con una o due prolun-
ghe a fissaggio frontale; fornite separate,
corredate di sacca in tessuto per riporle.

Dimensioni: H 76 cm

Spessore piano: 4 cm

Piano sagomato fin. Oak - Groove

Prolunga con bordo Dritto

EXTENDIBLE

Extending table, with two front-fastening
extensions, supplied separately, together
with fabric storage bag.

Dimensions: H 76 cm

Table top thickness: 4 cm

Shaped profile: OAK - GROOVE

Leaf with linear profile

VERLÄNGERBAR

Fester Tisch mit oder zwei Verlängerungplatten
die am Tischende befestigt werden. Auf-
bewahrung der Ansteckplatten, in einem
Stoffsack.

Maße: H 76 cm

Dicke der Platte: 4 cm Oak - Groove

Dimensioni / Dimensions / Maße

Chiuso / Closed / Geschlossen

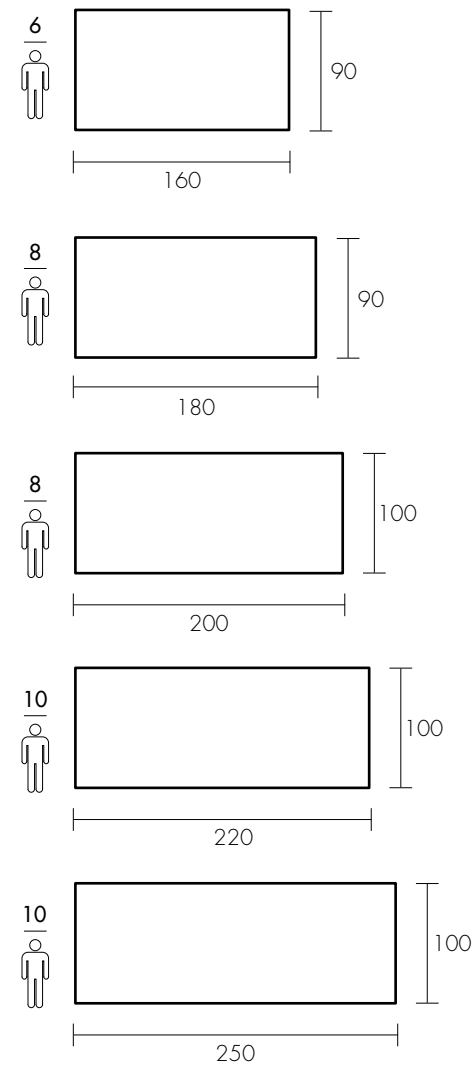

Aperto (1 allunga) / Open (1 ext.) / Offen (1 Verlängerung)

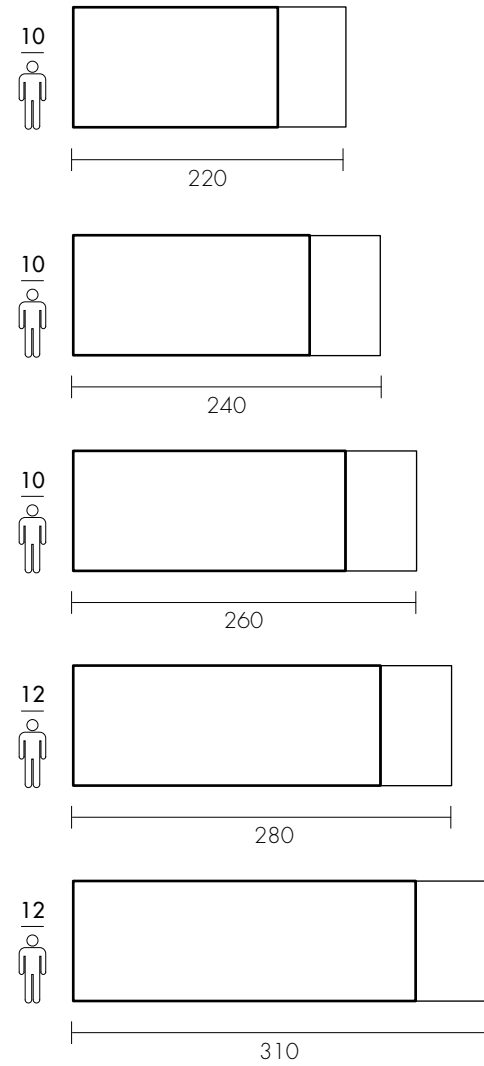

Aperto (2 allunghe) / Open (2 ext.) / Offen (2 Verlängerungen)

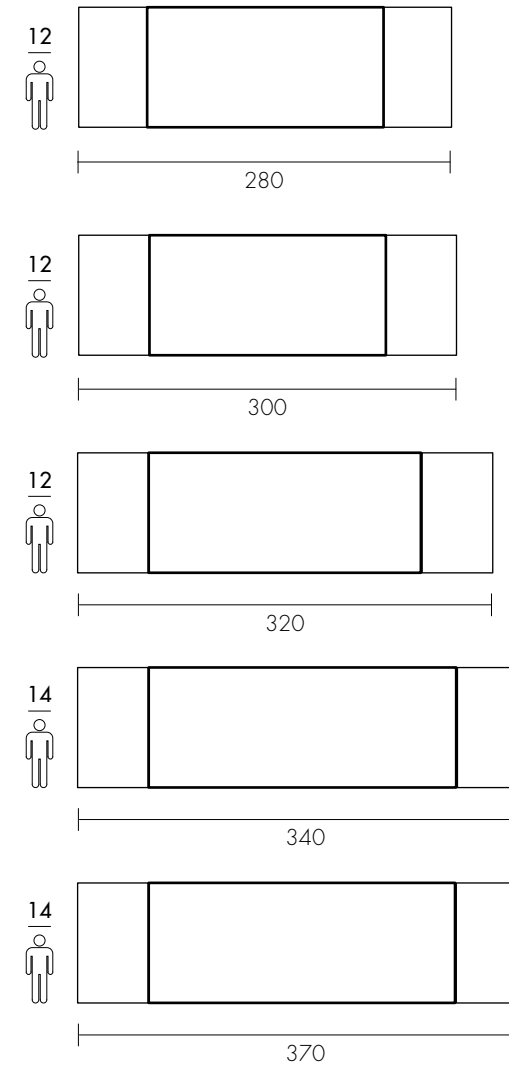

Chiuso / Closed / Geschlossen

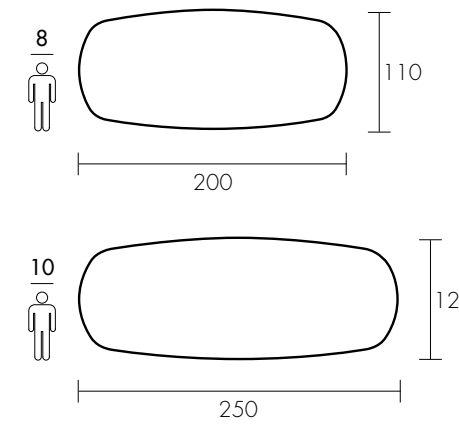

Aperto (1 allunga) / Open (1 ext.) / Offen (1 Verlängerung)

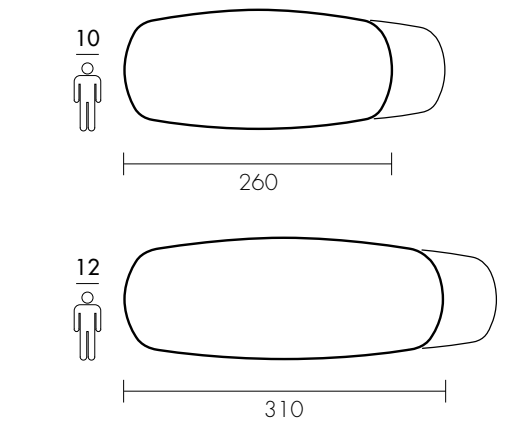

Aperto (2 allunghe) / Open (2 ext.) / Offen (2 Verlängerungen)

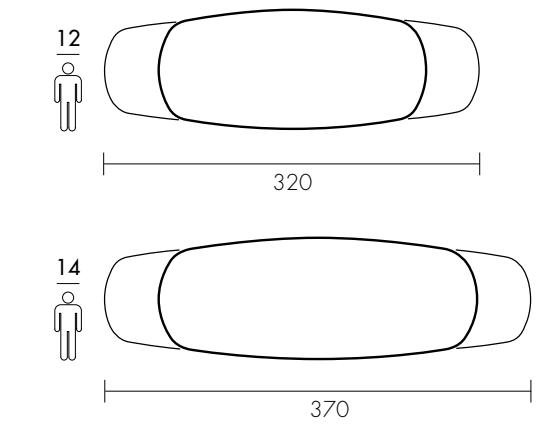



FGF MOBILI

FGF srl

Via Parnieri, 13

33098 Valvasone Arzene (Pn) ITALY

Tel. +39 0434 899618

Fax +39 0434 899714

www.fgfmobili.it

info@fgfmobili.it

TABLES

FGF MOBILI 



TABLES 2



TABLES

STYLE

MOOD

SQUARE

CURVE

BUTTERFLY

SLOPING

BLOCK

TESS-VESSNA

Una poesia scritta sul legno

Mio nonno sapeva leggere e scrivere.

Per sua moglie scrisse una poesia d'amore.

Le costruì il letto di nozze.

Una testiera altissima come la prua di una barca,
impiallacciata con venature a specchio.

La pediera bombata e lucida era la poppa di un piroscifo.

Lungo le cornici correva un intarsio, liscio come se fosse dipinto.

Un nastro si avvolgeva mostrando il verso.

S'incrociavano essenze diverse che si alternavano sempre uguali,
come se lui avesse voluto dirle:
non dimenticarlo, i nostri giorni insieme saranno così,
alcuni chiari, altri più scuri,
ma quel che li tiene assieme è questo disegno che si ripete
con infinita pazienza.

Mio nonno scriveva poesie.



MINI
MAL
DE
SI
GN





SOLO LEGNO
MASSELLLO



cod. E78Y
TAVOLO STYLE, fin. GROOVE / STYLE TABLE, GROOVE fin.
250x100x76H





cod. E964
PROLUNGA TAVOLO, fin. GROOVE
TABLE EXTENSION, GROOVE fin.
60x100
in foto 2 prolunghe



STYLE

ALLUNGABILE

Tavolo fisso. Optional con una o due prolun-
ghe a fissaggio frontale; fornite separate,
corredate di sacca in tessuto per riporle.

Dimensioni: H 76 cm
Altezza da terra a sottotavolo: 72 cm
Legno Massello, spessore piano: 4 cm

Piano fin. Oak con bordo Dritto
Piano fin. Groove con bordo Scortecciato
Prolunga solo Oak con bordo Dritto

EXTENDIBLE

Extending table, with two front-fastening
extensions, supplied separately, together
with fabric storage bag.

Dimensions: H 76 cm
Height from the floor: 72 cm
Hardwood; table top thickness: 4 cm

OAK finish profile: Square-Linear
GROOVE finish profile: Natural Irregular
Leaf only OAK with linear profile

VERLÄNGERBAR

Fester Tisch mit oder zwei Verlängerungplatten
die am Tischende befestigt werden.
Aufbewahrung der Ansteckplatten, in einem
Stoffsack.

Maße: H 76 cm
Abstand vom Boden: 72 cm
Massivholz; Dicke der Platte: 4 cm

Dimensioni / Dimensions / Maße

Chiuso / Closed / Geschlossen

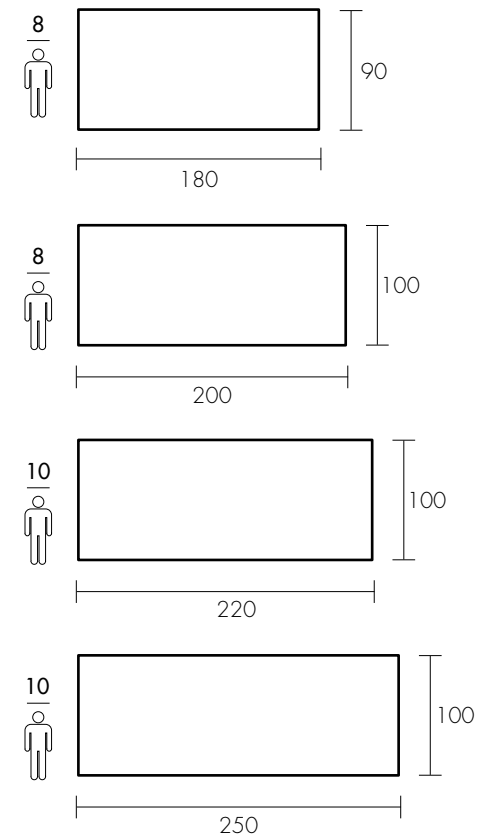

Aperto (1 allunghe) / Open (1 ext.) / Offen (1 Verlängerung)

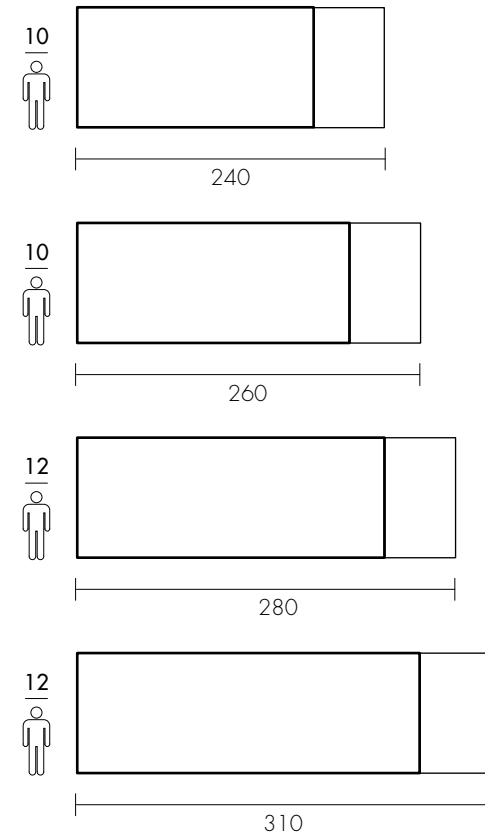

Aperto (2 allunghe) / Open (2 ext.) / Offen (2 Verlängerungen)

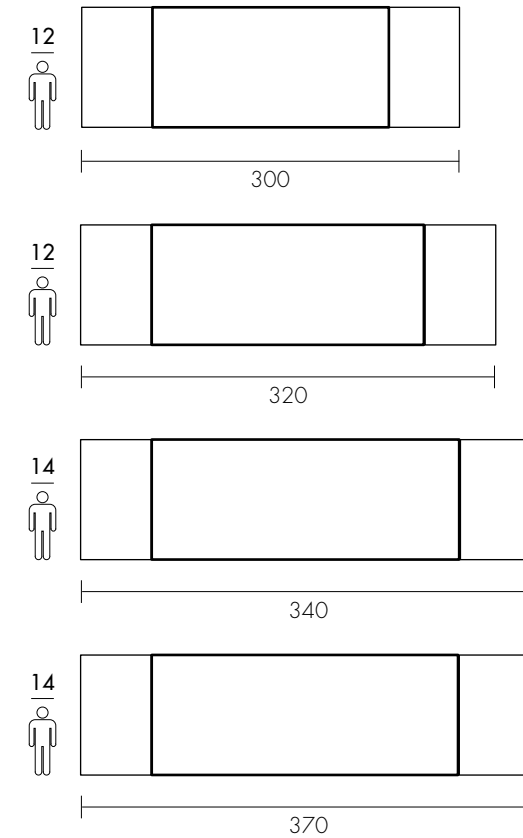

STYLE
MOOD
SQUARE
CURVE
BUTTERFLY
SLOPING
BLOCK
TESS-VESSNA

Oggi numerosi sono i motivi di riflessione che ci portano verso una coscienza più ecologica. Ecco perché abbiamo ritenuto opportuno usare materiali definiti EcoFriendly.

Sappiamo che niente richiama di più alla natura della bellezza del legno. Sappiamo quanto sia importante l'equilibrio che il "verde" conferisce alla nostra vita.

Da queste considerazioni nasce il rispetto e la giusta attenzione per il legno che lavoriamo e per le foreste che lo generano.





cod. E65D
TAVOLO MOOD, allungabile con prolunga interna, fin. GROOVE / MOOD TABLE, GROOVE fin.
160x90x75H



cod. E65D
TAVOLO MOOD, allungabile con prolunga interna, fin. GROOVE / MOOD TABLE, GROOVE fin.
160x90x75H, allungato 220 (telaio legno con guide metalliche)





cod. E66D
TAVOLO MOOD,
allungabile con prolunga interna, fin. GROOVE /
MOOD TABLE, GROOVE fin.
180x90x75H

cod. K25S
SEDIA TESS, fin. OAK / TESS CHAIR, OAK fin.
45x50x87H



cod. E66D
TAVOLO MOOD, allungabile con prolunga interna, fin. GROOVE / MOOD TABLE, GROOVE fin.
180x90x75H, allungato 240 (telaio legno con guide metalliche)

cod. K25S
SEDIA TESS, fin. OAK / TESS CHAIR, OAK fin.
45x50x87H



cod. D66D
TAVOLO MOOD, allungabile con prolunga interna, fin. WILD
MOOD TABLE, internal leaf, WILD fin.
180x90x75H





TAVOLO MOOD
Finitura WILD / WILD Finish
Piano in Legno Massello
Lavorazione Piano con Pialatura a Mano



cod. D66D
TAVOLO MOOD, allungabile con prolunga interna, fin. WILD / MOOD TABLE, internal leaf, WILD fin.
180x90x75H allungato 240 (telaio legno con guide metalliche)

TAVOLO MOOD
Finitura WILD / *WILD Finish*
Piano in Legno Massello
Lavorazione Piano con Piattatura a Mano



MOOD

ESTENSIBILE

Tavolo estensibile, con un piano aggiuntivo alloggiato all'interno. Movimento di estensione su guide in metallo.

Dimensioni: H 75 cm

Distanza tra le due gambe: L -26 cm

Altezza da terra a sottotavolo: 64,5 cm

Legno Massello, spessore piano: 2,5 cm

Dimensione gamba: 13x6,5 cm

EXPANDABLE

Expandable table, with additional table top housed inside.

Expansion mechanism on iron runners.

Dimensions: H 75 cm

Distance between the two legs: W -26 cm

Height from the floor: 64,5 cm

Hardwood; table top thickness: 2,5 cm

Table leg dimensions: 13x6,5 cm

AUSZIEHBAR

Auszugsvariante, mit einer oder zwei Einlegeplatte die im innenraum des Tisches aufbewahrt wird. Die Einlegeplatte wird auf eine Eisen.

Maße: H 75 cm

Abstand der Beine: B -26 cm

Abstand vom Boden: 64,5 cm

Massivholz; Dicke der Platte: 2,5 cm

Bein: 13x6,5 cm

Dimensioni / Dimensions / Maße

Chiuso / Closed / Geschlossen

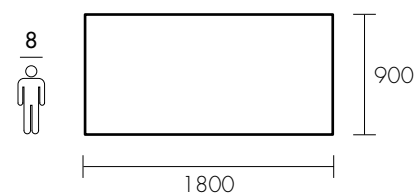
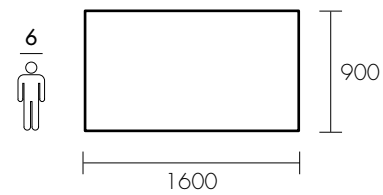
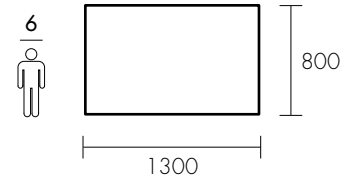

Aperto (1 allunga) / Open (1 ext.) / Offen (1 Verlängerung)

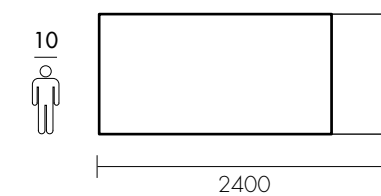
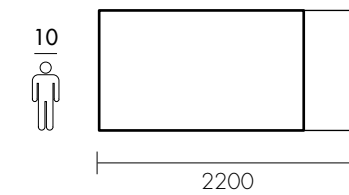
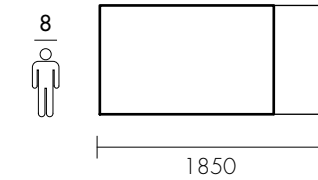

STYLE

MOOD

SQUARE

CURVE

BUTTERFLY

SLOPING

BLOCK

TESS-VESSNA

Il design che caratterizza i nostri mobili si potrebbe definire in due parole: Design Forever.

La linearità, la pulizia formale della collezione Square, caratteristica della maggior parte dei nostri mobili, è generatrice di quella vera eleganza che solo la semplicità può dare, una eleganza senza tempo.



cod. E987
TAVOLO SQUARE, allungabile con una prolunga interna, fin. GROOVE
SQUARE TABLE, one internal leaf, GROOVE fin.
205|255|x100x76H

PEZZI UNICI







cod. E19C
PANCA PIEDE VETRO, spessore piano e struttura 40 mm, fin. GROOVE
BENCH GLASS LEGS, structure and top thickness 40 mm, GROOVE fin.
190x40x45H

cod. E39C
PANCA PIEDE LEGNO CENTRALI, spessore piano e struttura 40 mm, fin. GROOVE
BENCH WOOD LEGS, structure and top thickness 40 mm, GROOVE fin.
190x40x45H



GROOVE
FINISH



cod. E987
TAVOLO SQUARE, con due allunghe da 50 cm, fin. GROOVE
SQUARE TABLE, with two 50 cm leaf, GROOVE fin.
205(255)x100x76H allungato 305 cm



cod. E961
ALLUNGA opzionale per estensibile, fin. GROOVE
Optional extensible LEAF, GROOVE fin.
50x100x2H





cod. E985
TAVOLO SQUARE FISSO, fin. GROOVE
SQUARE TABLE, GROOVE fin.
205x100x76H

cod. E964
PROLUNGA TAVOLO, fin. GROOVE
TABLE EXTENSION, GROOVE fin.
60x100

SQUARE

FISSO + PROLUNGHE

Tavolo fisso. Optional con una o due prolunghe a fissaggio frontale; fornite separate, corredate di sacca in tessuto per riporle.
 Dimensioni: H 76 cm
 Distanza tra le due gambe: L -24 cm
 Altezza da terra a sottotavolo: 63 cm
 Legno Massello, spessore piano: 4 cm
 Dimensione gamba: 12x12 cm

EXTENDIBLE

Extending table, with two front-fastening extensions, supplied separately, together with fabric storage bag.
 Dimensions: H 76 cm
 Distance between the two legs: W -24 cm
 Height from the floor: 63 cm
 Hardwood; table top thickness: 4 cm
 Table leg dimensions: 12x12 cm

VERLÄNGERBAR

Fester Tisch mit oder zwei Verlängerungplatten die am Tischende befestigt werden.
 Aufbewahrung der Ansteckplatten, in einem Stoffsack.
 Maße: H 76 cm
 Abstand der Beine: B -24 cm
 Abstand vom Boden: 63 cm
 Massivholz; Dicke der Platte: 4 cm
 Bein: 12x12 cm

Dimensioni / Dimensions / Maße

Chiuso / Closed / Geschlossen

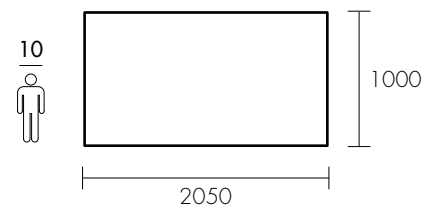
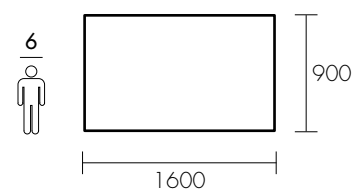
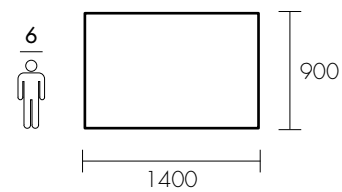
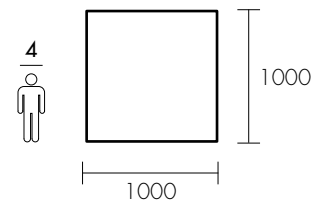

Aperto (1 allunga) / Open (1 ext.) / Offen (1 Verlängerung)

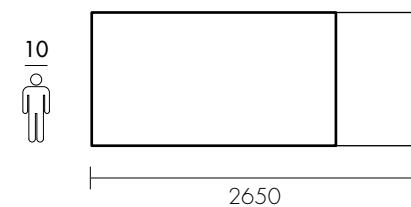
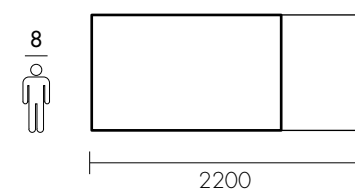
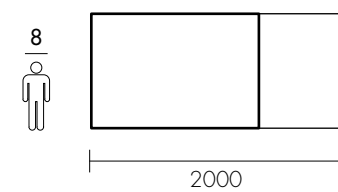
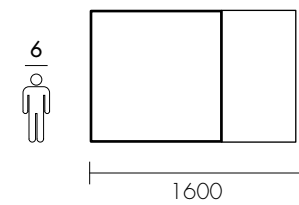

Aperto (2 allunghe) / Open (2 ext.) / Offen (2 Verlängerungen)

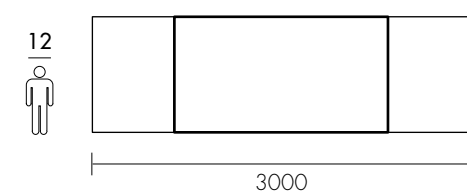
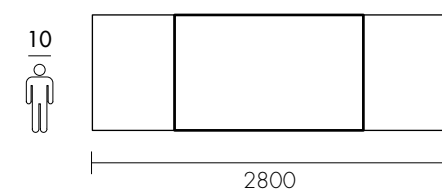
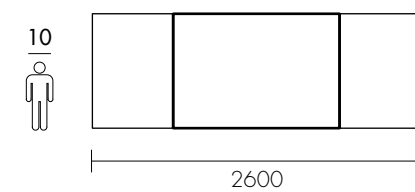
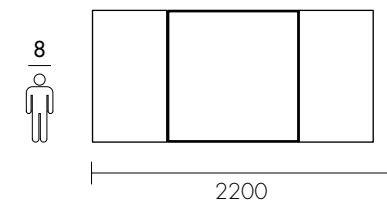

ESTENSIBILE

Tavolo estensibile con due allunghe interne.
 Allunga interna misura 50 cm.
 Optional una prolunga a fissaggio frontale; corredata di sacca in tessuto per riporla.
 Dimensioni: H 76 cm
 Altezza da terra a sottotavolo: 72 cm
 Legno Massello, spessore piano: 4 cm
 Piano fin. Oak con bordo Dritto
 Piano fin. Groove con bordo Scortecciato
 Prolunga solo Oak con bordo Dritto

EXTENDIBLE

Extending table, with two internal extensions.
 Internal leaf measures 50 cm.
 Dimensions: H 76 cm
 Height from the floor: 72 cm
 Hardwood; table top thickness: 4 cm
 OAK finish profile: Square-Linear
 GROOVE finish profile: Natural Irregular
 Leaf only OAK with linear profile

VERLÄNGERBAR

Fester Tisch mit oder zwei Verlängerungplatten die am Tischende befestigt werden.
 Maße: H 76 cm
 Abstand vom Boden: 72 cm
 Massivholz; Dicke der Platte: 4 cm

Dimensioni / Dimensions / Maße

Chiuso / Closed / Geschlossen

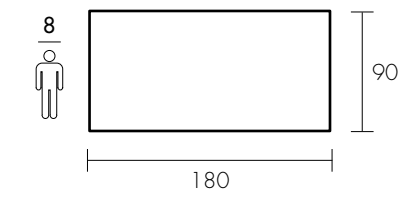
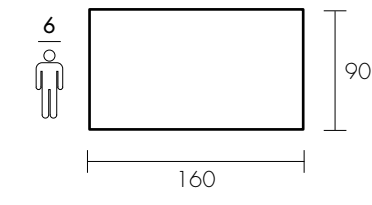

Aperto (1 allunga) / Open (1 ext.) / Offen (1 Verlängerung)

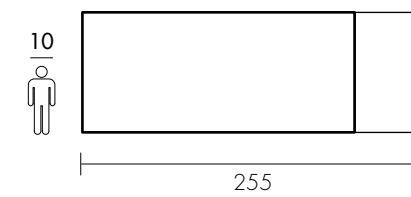
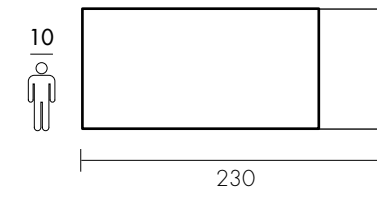
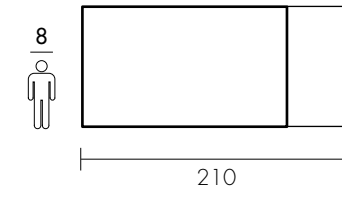

Aperto (2 allunghe) / Open (2 ext.) / Offen (2 Verlängerungen)

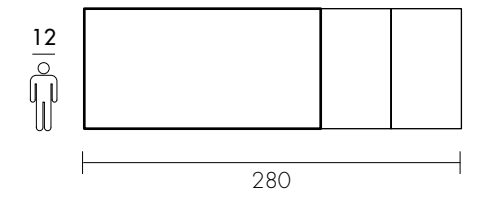
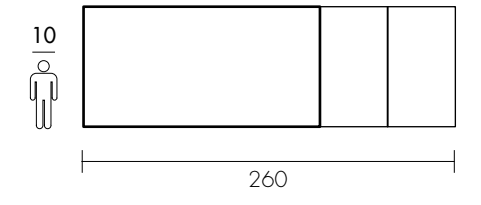

STYLE

MOOD

SQUARE

CURVE

BUTTERFLY

SLOPING

BLOCK

TESS-VESSNA

○gni mobile di FGF ha una storia fatta di natura e di uomini.

Possederne uno vuol dire far entrare nella nostra casa un elemento di "verde", uno scorcio di vita di tutti coloro che, con le loro mani, hanno sapientemente trasformato le grezze assi in un mobile di design.

Vuol dire essere consapevoli di possedere un pezzo unico e saper apprezzare la sensazione di solidità duratura che solo il vero legno può trasmettere.



cod. K951
TAVOLO CURVE, fin. OAK / CURVE TABLE, OAK fin.
160x90x75H



FOR
ME
AR
MO
NIO
SE





cod. K972
TAVOLO BUTTERFLY, fin. OAK /
BUTTERFLY TABLE, OAK fin.
180x90x75H



LEG
NO
MA
SSI
CC
IO



cod. K942
TAVOLO SLOPING, fin. OAK / SLOPING TABLE, OAK fin.
180x90x75H



CURVE / BUTTERFLY / SLOPING

ALLUNGABILE

Tavolo fisso. Optional con una o due prolunghe a fissaggio frontale; fornite separate, corredate di sacca in tessuto per riporle.

Dimensioni: H 75 cm

Distanza tra le due gambe: L -24 cm

Altezza da terra a sottotavolo: 63 cm

Legno Massello, spessore piano: 4 cm

Dimensione gamba: 12x12 cm

EXTENDIBLE

Extending table, with two front-fastening extensions, supplied separately, together with fabric storage bag.

Dimensions: H 75 cm

Distance between the two legs: W -24 cm

Height from the floor: 63 cm

Hardwood; table top thickness: 4 cm

Table leg dimensions: 12x12 cm

VERLÄNGERBAR

Fester Tisch mit oder zwei Verlängerungplatten die am Tischende befestigt werden.

Aufbewahrung der Ansteckplatten, in einem Stoffsack.

Maße: H 75 cm

Abstand der Beine: B -24 cm

Abstand vom Boden: 63 cm

Massivholz; Dicke der Platte: 4 cm

Bein: 12x12 cm

Dimensioni / Dimensions / Maße

Chiuso / Closed / Geschlossen

Aperto (1 allunga) / Open (1 ext.) / Offen (1 Verlängerung)

Aperto (2 allunghe) / Open (2 ext.) / Offen (2 Verlängerungen)

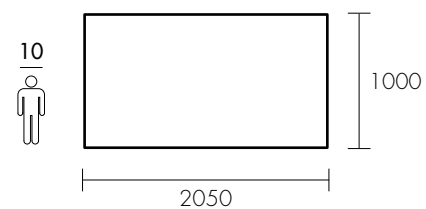
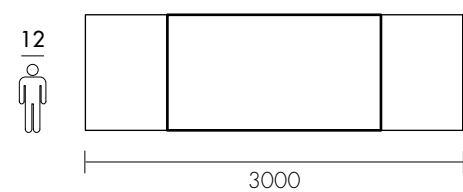
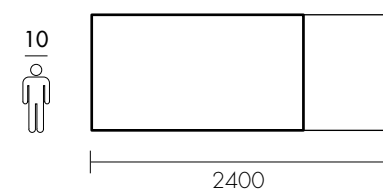
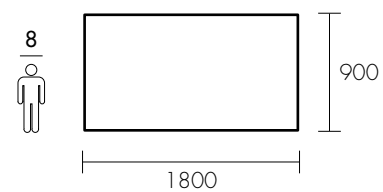
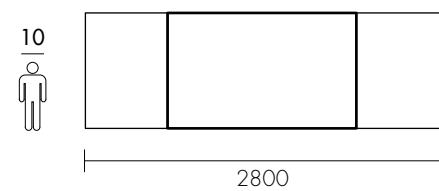
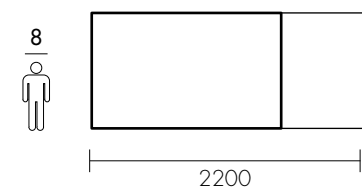
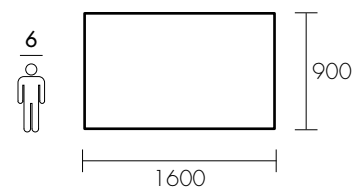
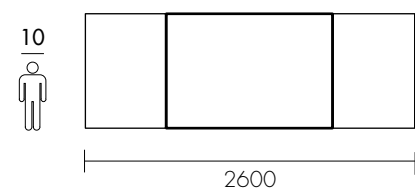
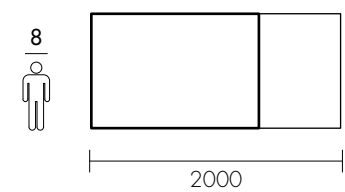
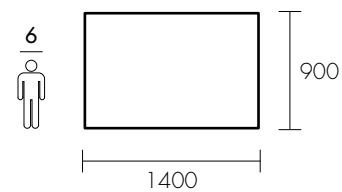
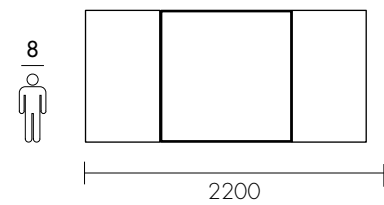
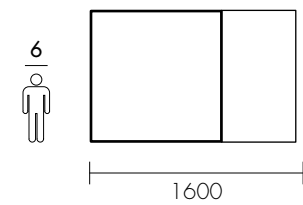
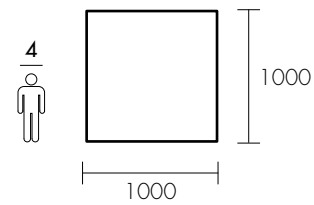

STYLE
MOOD
SQUARE
CURVE
BUTTERFLY
SLOPING
BLOCK
TESS-VESNA

La casa è la naturale destinazione dei nostri prodotti. Casa intesa come ambiente importante, funzionale, ma anche espressione della personalità di chi la abita.

Scegliere di arredare il nostro spazio quotidiano con un mobile in legno è una decisione spesso vissuta con grande passione.

I destinatari privilegiati dei nostri prodotti sono persone che amano la naturalezza del legno e le particolarità delle lavorazioni artigianali, caratteristiche sempre presenti nei nostri prodotti.



cod. K36K
TAVOLO BLOCK, fin. OAK / BLOCK TABLE, OAK fin.
180x90x75H



cod. K36K
TAVOLO BLOCK, fin. OAK / BLOCK TABLE, OAK fin.
180x90x75H



cod. K37K
TAVOLO BLOCK, fin. OAK / BLOCK TABLE, OAK fin.
200x100x75H

cod. K15A
SEDIA VESNA, fin. OAK / VESNA CHAIR, OAK fin.
45x50x87H



cod. K37K
TAVOLO BLOCK, allungabile con prolunga interna (telaio in alluminio), fin. OAK / BLOCK TABLE, OAK fin.
200x100x75H, allungato 300

cod. K15A
SEDIA VESNA, fin. OAK / VESNA CHAIR, OAK fin.
45x50x87H

cod. T36K
TAVOLO BLOCK, fin. MUST / BLOCK TABLE, MUST fin.
Telaio Legno 180x90x75H





cod. T36K
TAVOLO BLOCK, fin. MUST / BLOCK TABLE, MUST fin.
180x90x75H allungato 240 (telaio legno con guide metalliche)





MU ST FI NI SH

cod. T36K
TAVOLO BLOCK, fin. MUST
BLOCK TABLE, MUST fin.
180x90x75H allungato 240
(telaio legno con guide metalliche)



BLOCK

ESTENSIBILE

Tavolo estensibile, con due piani aggiuntivi alloggiati all'interno. Movimento di estensione su telaio in alluminio.
 Dimensioni: H 75 cm
 Distanza tra le due gambe: L -18 cm
 Altezza da terra a sottotavolo: 66 cm
 Legno Massello, spessore piano: 2,5 cm
 Dimensione gamba 9x9 cm

EXPANDABLE

Expandable table, with additional table top housed inside. Expansion mechanism on aluminium frame.
 Dimensions: H 75 cm
 Distance between the two legs: W -18 cm
 Height from the floor: 66 cm
 Hardwood; table top thickness: 2,5 cm
 Table leg dimensions: 9x9 cm

AUSZIEHBAR

Auszugsvariante, mit einer oder zwei Einlegeplatte die im innenraum des Tisches aufbewahrt wird. Die Einlegeplatte wird auf eine Aluminiumschiene bewegt.
 Maße: H 75 cm
 Abstand der Beine: L -18 cm
 Abstand vom Boden: 66 cm
 Massivholz; Dicke der Platte: 2,5 cm
 Bein: 9x9 cm

ESTENSIBILE

Tavolo estensibile, con un piano aggiuntivo alloggiato all'interno. Movimento di estensione su telaio in legno con guide in metallo.
 Dimensioni: H 75 cm
 Distanza tra le due gambe: L -18 cm
 Altezza da terra a sottotavolo: 66 cm
 Legno Massello, spessore piano: 2,5 cm
 Dimensione gamba: 9x9 cm

EXPANDABLE

Expandable table, with additional table top housed inside. Expansion mechanism on iron runners, on the wood frame.
 Dimensions: H 75 cm
 Distance between the two legs: W -18 cm
 Height from the floor: 66 cm
 Hardwood; table top thickness: 2,5 cm
 Table leg dimensions: 9x9 cm

AUSZIEHBAR

Auszugsvariante, mit einer oder zwei Einlegeplatte die im innenraum des Tisches aufbewahrt wird.
 Maße: H 75 cm
 Abstand der Beine: B -18 cm
 Abstand vom Boden: 66 cm
 Massivholz; Dicke der Platte: 2,5 cm
 Bein: 9x9 cm

OAK - GROOVE

Dimensioni / Dimensions / Maße

Chiuso / Closed / Geschlossen

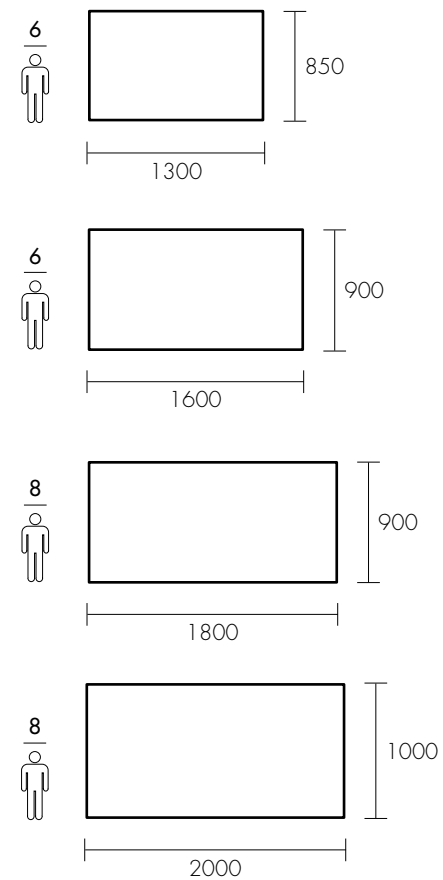

Aperto (1 allunga) / Open (1 ext.) / Offen (1 Verlängerung)

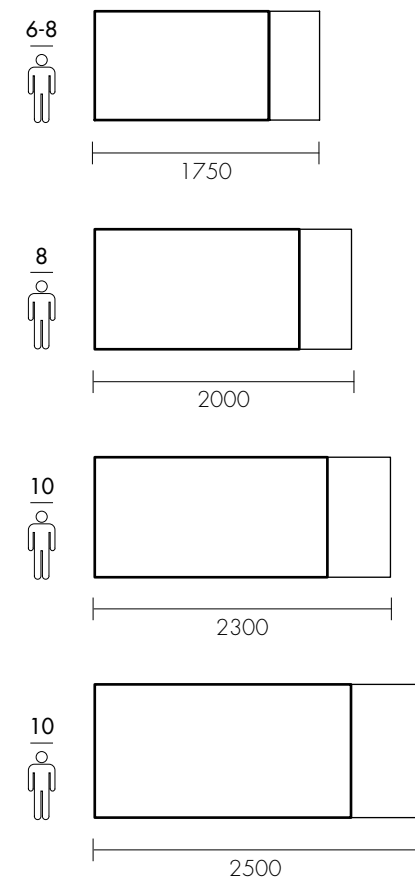

Aperto (2 allunghe) / Open (2 ext.) / Offen (2 Verlängerungen)

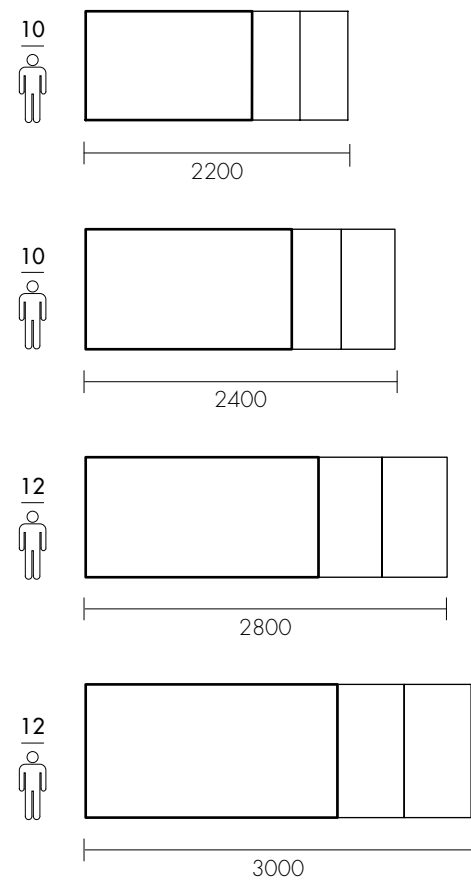

MUST

Dimensioni / Dimensions / Maße

Chiuso / Closed / Geschlossen

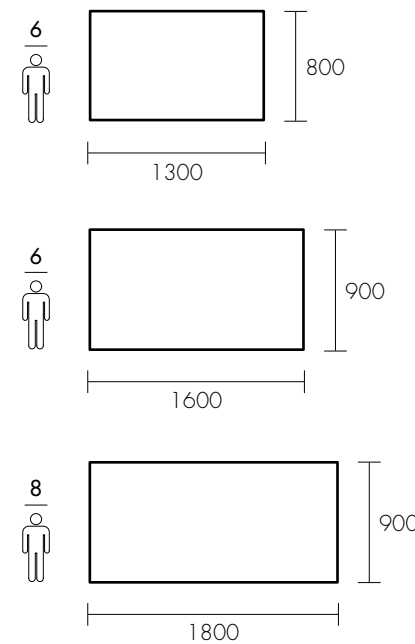

Aperto (1 allunga) / Open (1 ext.) / Offen (1 Verlängerung)

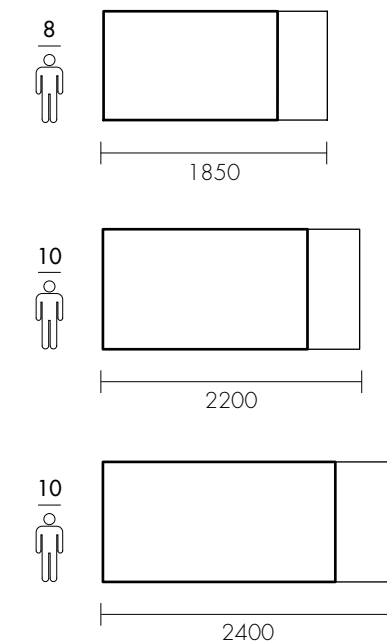

STYLE
MOOD
SQUARE
CURVE
BUTTERFLY
SLOPING
BLOCK
TESS-VESNA

Today there are many signs of this modern trend, as are several reasons that lead us towards a more environmentally conscious. That's why we felt it appropriate to use materials defined EcoFriendly.

We know that nothing draws more on the nature of the beauty of wood. We know how important the balance that the "green" gives to our lives. From these considerations comes our respect and proper attention to the wood and for forest that generate it.

The pleasure of spending our everyday life with a FGF furniture derives from the awareness of its uniqueness, that the lasting impression of solidity that only real wood can be transmitted.



SIM
PLE
DE
SI
GN



cod. K25S
SEDIA TESS, fin. OAK / TESS CHAIR, OAK fin.
45x50x87H

TESS

OAK



Sedia dal design leggero e moderno, adatta ad arredare la sala da pranzo o lo studio. Tess offre all'ospite un comodo appoggio grazie alla seduta sagomata ed alla spalliera leggermente curvata e inclinata all'indietro. Tess, la sedia senza tempo per eccellenza, ideale per trovare la combinazione adatta ad ogni stile.

A chair with a light and modern design, suitable for the dining room or study. Tess offers diners comfortable respite thanks to the shaped seat and the slightly curving backrest that tilts backwards. Tess, a timeless classic, the ideal partner for any style.

Der Stuhl hat ein leichtest und modernes Design, passt zum Essbereich sowie ins Arbeitszimmer. Der Stuhl Tess bietet ein bequemen Sitzkomfort durch die geformte und leicht gekippte Form der Rückenlehne. Der Stuhl Tess ist zeitlos, ideal für die Kombination, die zu jedem Stil passt.

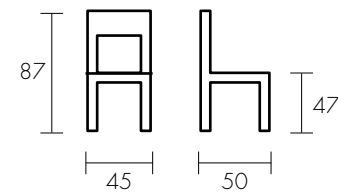

Finiture / Finishes / Farbe



OAK



LE
GNO
RE
SIS
TEN
TE



cod. K15A
SEDIA VESNA, fin. OAK / VESNA CHAIR, OAK fin.
45x50x87H

VESNA

OAK



Vesna è una sedia dalle linee moderne con un richiamo alla tradizione, grazie alla struttura dello schienale, adatta ad arredare la sala da pranzo o lo studio. La sua caratteristica principale è l'ampia spalliera avvolgente ed ergonomica, che abbinata al sedile dalle dimensioni generose, garantisce un elevato comfort di seduta.

Vesna is a modern chair with some traditional influence, thanks to the structure of the backrest, ideal for use in both the dining room and in the study. Its distinguishing trait is the broad ergonomically-designed wraparound backrest, which combined with the generous seat guarantees a truly comfortable chair.

Vesna ist ein Stuhl aus der modernen Linie mit Appell an Tradition, dank der Struktur der Rückenlehne, passt er sehr gut in den Essbereich sowie ins Arbeitszimmer. Das Hauptmerkmal liegt bei der großen Rückenlehne und ergonomisch großzügig gestaltetem Sitz, kombiniert garantiert der Stuhl einen hohen Sitzkomfort.

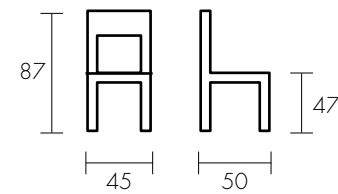

Finiture / Finishes / Farbe



FINISHES

OAK

FINITURE / FINISHES / FARBE



MUST

FINITURE / FINISHES / FARBE



GROOVE

FINITURE / FINISHES / FARBE



WILD

FINITURE / FINISHES / FARBE



Le finiture e le tinte qui rappresentate sono da ritenersi indicative e non vincolanti. La presenza di tonalità diverse fra i vari elementi sono da ritenersi normali caratteristiche dei mobili in legno.

Finishes shown here are only indicative and not binding. Other color tonalities in the different pieces of the furniture are normal characteristics of the wood furniture.

Le finiture e le tinte qui rappresentate sono da ritenersi indicative e non vincolanti. La presenza di tonalità diverse fra i vari elementi sono da ritenersi normali caratteristiche dei mobili in legno.

Finishes shown here are only indicative and not binding. Other color tonalities in the different pieces of the furniture are normal characteristics of the wood furniture.



FGFMOBILI

FGF srl
Via Parnieri, 13
33098 Valvasone Arzene (Pn) ITALY

Tel. +39 0434 899618
Fax +39 0434 899714

www.fgfmobili.it
info@fgfmobili.it

TABLES

FGFMOBILI 